

Sensor-PLC Connection System

SC SERIES

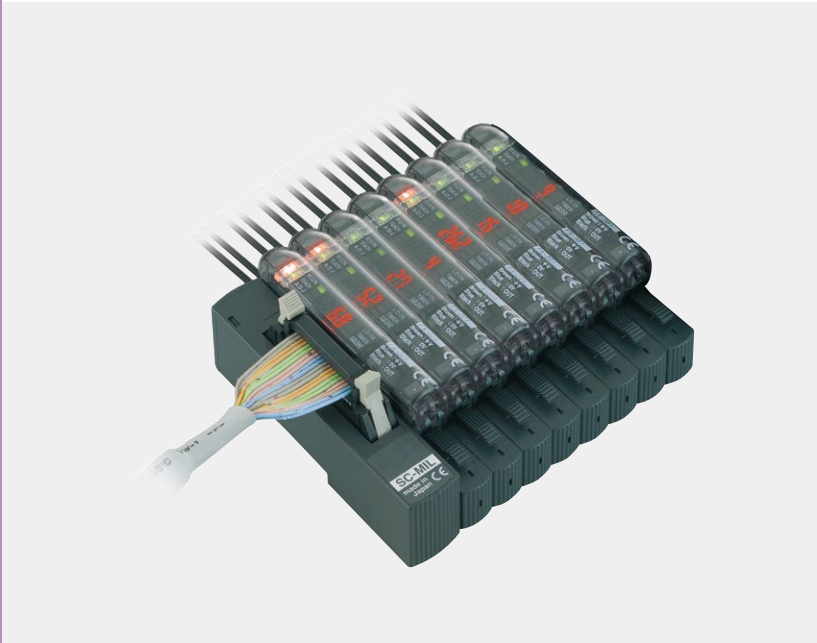



Up to 16 I/O devices can be connected at once using MIL connectors

Up to 16 I/O devices can be connected at once using MIL connectors

Up to 16 units, such as fiber sensors **FX-500/410/300** series, digital laser sensors **LS-500/400** series, digital pressure sensors **DPS-401/402** and compact inductive proximity sensors **GA-311**, can be connected side-by-side configuration without tools in a main unit. Also, dispersed mounting is possible using a separate unit. In addition, using the connector input / output extension unit, photoelectric sensors, micro photoelectric sensors, inductive proximity sensors, pressure sensors, or any other type of sensor or switch can be one-touch connected to an output device.

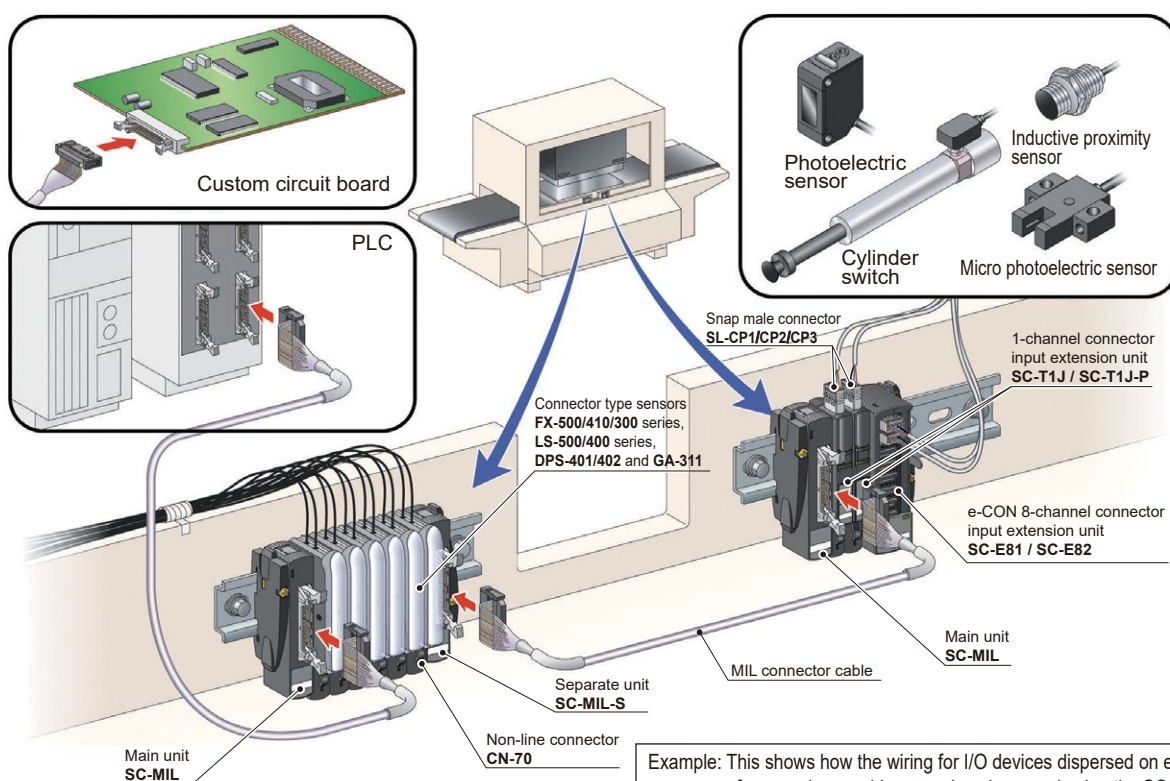

Example: This shows how the wiring for I/O devices dispersed on either side of processing machines can be wire-saved using the SC series.

ORDER GUIDE



Designation	Appearance	Model No.	Description	
Main unit		SC-MIL	The MIL connector allows up to 16 input / output device connections to a PLC or custom circuit board, in a single step.	
Separate unit		SC-MIL-S	Distributed installations are possible through the use of a main unit and MIL connectors.	
1-channel connector input extension unit		SC-T1J	For NPN output devices	Allows the connection of input device, such as sensor or switch. Incorporates a power indicator and an input signal indicator (1 ch).
		SC-T1J-P	For PNP output devices	
e-CON 1-channel connector input extension unit		SC-E1	This extension unit can be connected to commercially available devices including an NPN output type or DC 2-wire type sensor (Note 1). Includes power and input signal indicators (for one channel).	
e-CON 8-channel connector input extension unit		SC-E81	This extension unit can be connected to eight NPN output type devices. Includes power and input signal indicators (for eight channels).	
e-CON 8-channel connector input extension unit (Without an input signal indicator)		SC-E82	This extension unit can be connected to eight commercially available devices and output devices including an NPN/PNP output type sensors, switches or DC 2-wire sensors. Includes a power indicator. Does not include an input signal indicator.	
Non-line connector		CN-70	This one-touch connector is used to connect the main unit to the following devices: The FX-500/410/300 fiber sensor, the LS-500/400 laser sensor, digital pressure sensor DPS-401/402 , the GA-311 compact inductive proximity sensor, the FX-CH(-P) bank selection unit and 1-channel connector input extension unit. (Note 2)	
End plates		MS-DIN-E 2 pcs. per set	When SC series units are connected on a DIN rail, these end plates clamp amplifiers into place on both sides. Make sure to use end plates when cascading multiple amplifiers together.	

Notes: 1) Conditions of connectable DC 2-wire type input device

- Leak current: 1 mA or less (when the power is OFF), Offset voltage: 3 V or less (when the power is ON)
- Product whose load current range includes 5 to 8 mA

2) The 2-output type can output the output 1 (OUT 1) only from **SC-MIL**. There is no connection for output 2 (OUT2).

OPTIONS

Designation	Appearance	Model No.	Description	
4-pin type snap male connector (Note)		SL-CP1 (White) 10 pcs. per set	For 0.08 to 0.2 mm ² (Conductor cross-section area) Wire diameter: ø0.7 to ø1.2 mm ø0.028 to ø0.047 in	Snap male connectors are utilized to connect input / output devices to the 1-channel connector input extension unit. The 1-channel connector input extension unit includes one SL-CP1 .
		SL-CP2 (Black) 10 pcs. per set	For 0.3 mm ² (Conductor cross-section area) Wire diameter: ø1.1 to ø1.6 mm ø0.043 to ø0.063 in	
		SL-CP3 (Greenish blue) 10 pcs. per set	For 0.5 mm ² (Conductor cross-section area) Wire diameter: ø1.7 to ø2.5 mm ø0.067 to ø0.098 in	
Compatible installation tool for SC		SC-BUX10 10 pcs. per set	This tool is used to install SC-MIL-S into the SC-GU3 series.	

Note: Exclusive pliers are also available.

SPECIFICATIONS

Sensor units

Item	Type	Main unit	Separate unit
	Model No.	SC-MIL	SC-MIL-S
CE marking directive compliance		EMC Directive, RoHS Directive	—
Supply voltage		12 to 24 V DC $\pm 10\%$ (Note 2)	Depends on the supply voltage from SC-MIL
Allowable through current (Note 3)		2 A or less (Same as maximum permissible current consumption of all units connected to SC-MIL .)	1 A or less (Same as maximum permissible current consumption of all units connected to SC-MIL-S .)
Signal channel No.		Connectable up to 16 channels (The signal from up to 16th point (counting from unit adjacent to SC-MIL) of all units connected to SC-MIL is transferred. However, the signal thereafter is not transferred. Note that SC-MIL and SC-MIL-S do not occupy any signal point.)	
Max. distance between units		10 m 32.808 ft or less (the distance between SC-MIL and PLC and that between SC-MIL and SC-MIL-S put together)	
Ambient temperature		-10 to +45 °C +14 to +113 °F (No dew condensation or icing allowed), Storage: -20 to +70 °C -4 to +158 °F	
Ambient humidity		35 to 85 % RH, Storage: 35 to 85 % RH	
Material		Enclosure: Heat-resistant ABS	
Net weight		25 g approx.	20 g approx.
Accessory		Connector protection seal: 1 pc.	

- Notes: 1) Where measurement conditions have not been specified precisely, the conditions used were an ambient temperature of +20 °C **+68 °F**.
 2) The plug-in sensor main unit **SC-MIL** incorporates a cable lead-out connector in addition to the MIL connector, which allows to receive the supply voltage from the separate power supply.
 3) When either the permissible current amount of power supply unit or the permissible current amount of cable to be connected is less than allowable through current value, adjust the current to the smallest value.

e-CON connector input extension unit

Item	Designation	e-CON 1-channel connector input extension unit
	Model No.	SC-E1
Supply voltage		12 to 24 V DC $\pm 10\%$
Current consumption		20 mA or less (with all indicators on) (Note 1)
Number of signals		1 input
Input		Connectable devices: NPN open-collector transistor output type (Input 1) and DC 2-wire output type (Input 2) sensors (Note 2), switches, and other devices Current supply for input device: 100 mA or less Input impedance: Approx. 17 k Ω (Input 1) or approx. 3.2 k Ω (Input 2)
Output		NPN open-collector transistor • Maximum sink current: 50 mA • Applied voltage: 30 V DC or less (between output and 0 V) • Residual voltage: 1.5 V or less (with sink current of 50 mA)
Power indicator		Green LED (lights up when the power is ON)
Input indicator		Green LED (lights up when input is being received by unit)
Ambient temperature		-10 to +55 °C +14 to +131 °F (No dew condensation or icing allowed), (if 4 to 7 units are connected in cascade: -10 to +50 °C +14 to +122 °F , if 8 to 16 units are connected in cascade: -10 to +45 °C +14 to +113 °F) Storage: -20 to +70 °C -4 to +158 °F
Ambient humidity		35 to 85 % RH, Storage: 35 to 85 % RH
Material		Enclosure: Flame-resistant PBT, Connector: Polyester
Weight		Net weight: 15 g approx., Gross weight: 40 g approx.
Accessory		Connector (e-CON): 1

- Notes: 1) Does not include current consumption or input current for connected input devices.
 2) Conditions of connectable DC 2-wire type input device
 • Leak current: 1 mA or less (when the power is OFF),
 Offset voltage: 3 V or less (when the power is ON)
 • Product whose load current range includes 5 to 8 mA

Connector input extension units

Item	Type	Connector input extension units	
		For NPN output devices	For PNP output devices
Model No.		1 channel	1 channel
		SC-T1J	SC-T1J-P
CE marking directive compliance		EMC Directive, RoHS Directive	
Supply voltage		12 to 24 V DC $\pm 10\%$	
Current consumption (Note 2)		20 mA or less (when all indicators light up)	
Signal channel No.		1 input	
Connectable device		NPN open-collector, or DC 2-wire output type sensor, or switch etc.	PNP open-collector, or DC 2-wire output type sensor, or switch etc.
Supply current for units (Note 3)		100 mA or less	
Power indicator		Green LED (Lights up when the power is ON)	
Input indicator		Green LED (Lights up when each channel input is ON)	
Ambient temperature		-10 to +45 °C +14 to +113 °F (No dew condensation or icing allowed), Storage: -20 to +70 °C -4 to +158 °F	
Ambient humidity		35 to 85 % RH, Storage: 35 to 85 % RH	
Material		Enclosure: Heat-resistant ABS	
Net weight		10 g approx.	
Accessory		SL-CP1 (Snap male connector): 1 pc.	

- Notes: 1) Where measurement conditions have not been specified precisely, the conditions used were an ambient temperature of +20 °C **+68 °F**.
 2) The current consumption and input current of the input unit connected are not included.
 3) Set the maximum current passing through input / output line to 50 mA or less.

SPECIFICATIONS

e-CON connector input extension unit

Designation	e-CON 8-channel connector input extension unit
Item / Model No.	SC-E81
Supply voltage	12 to 24 V DC $\pm 10\%$
Current consumption	60 mA or less (with all indicators on) (Note 1)
Number of signals	8 inputs (Note 2)
Input	Connectable devices: NPN open-collector transistor output type sensors, switches, and other devices Current supply for input devices: 800 mA or less (total for 8 inputs) Input impedance: 17 k Ω approx.
Output	NPN open-collector transistor • Maximum sink current: 50 mA • Applied voltage: 30 V DC or less (between output and 0 V) • Residual voltage: 1.5 V or less (with sink current of 50 mA)
Power indicator	Green LED (lights up when the power is ON)
Input indicator	8 green LEDs (light up when input is received from the corresponding channel)
Ambient temperature	-10 to +55 °C +14 to +131 °F (No dew condensation or icing allowed), (If 4 to 7 units are connected in cascade: -10 to +50 °C +14 to +122 °F, if 8 to 9 units are connected in cascade: -10 to +45 °C +14 to +113 °F) Storage: -20 to +70 °C -4 to +158 °F
Ambient humidity	35 to 85 % RH, Storage: 35 to 85 % RH
Material	Enclosure: Polycarbonate, Connector: Polyester
Weight	Net weight: 40 g approx., Gross weight: 85 g approx.

Notes: 1) Does not include current consumption or input current for connected input devices.

2) Uses eight channels of signaling, regardless of the number of connected input devices.

Non-line connector

Designation	Non-line connector
Item / Model No.	CN-70
Applicable unit	Refer to the list of " Applicable unit of non-line connector "
Supply voltage	Depends on the supply voltage from SC-MIL
Supply current for units	100 mA or less
Signal channel No.	1 channel
Ambient temperature	-10 to +45 °C +14 to +113 °F (No dew condensation or icing allowed) Storage: -20 to +70 °C -4 to +158 °F
Ambient humidity	35 to 85 % RH, Storage: 35 to 85 % RH
Material	Enclosure: ABS
Weight	Net weight: 4 g approx.

Note: Where measurement conditions have not been specified precisely, the conditions used were an ambient temperature of +20 °C +68 °F.

Designation	e-CON 8-channel connector input extension unit (without an input signal indicator)
Item / Model No.	SC-E82
Supply voltage	5 to 24 V DC $\pm 10\%$
Current consumption	7 mA or less
Number of signals	8 inputs (Note 1)
Input	Connectable devices: NPN/PNP open-collector transistor output type sensors, switches, etc. and commercially available devices and output devices including a DC 2-wire type sensor (Note 2) Current supply for input devices: 800 mA or less (total for 8 inputs)
Power indicator	Green LED (Lights up when the power is ON)
Ambient temperature	-10 to +55 °C +14 to +131 °F (No dew condensation or icing allowed), (If 4 to 7 units are connected in cascade: -10 to +50 °C +14 to +122 °F, if 8 to 9 units are connected in cascade: -10 to +45 °C +14 to +113 °F) Storage: -20 to +70 °C -4 to +158 °F
Ambient humidity	35 to 85 % RH, Storage: 35 to 85 % RH
Material	Enclosure: Polycarbonate, Connector: Polyester
Weight	Net weight: 40 g approx., Gross weight: 85 g approx.

Notes: 1) Uses eight channels of signaling, regardless of the number of connected input devices.

2) When using in combination with the **SC-GU3** series, it cannot use as a commercially available device including a DC 2-wire type sensor or output.

Applicable unit of non-line connector

Designation	Model No.	Description
1-channel input extension units	SC-T1J	For NPN output devices
	SC-T1J-P	For PNP output devices
Digital fiber sensors (Note)	FX-501/502	For NPN output devices
	FX-501P/502P	For PNP output devices
	FX-301B/301G FX-301H	For NPN output devices
	FX-301BP/301GP FX-301HP	For PNP output devices
	FX-411(B/G) FX-412(B/G)	For NPN output devices
	FX-411(B/G)P	For PNP output devices
Manually set fiber sensors	FX-311(B/G)	For NPN output devices
	FX-311(B/G)P	For PNP output devices
Digital fiber sensors for leak detection fiber / liquid detection fiber	FX-301-F	For NPN output devices
	FX-301P-F	For PNP output devices
Digital laser sensors (Note)	LS-501	For NPN output devices
	LS-501P	For PNP output devices
	LS-401/403	For NPN output devices
	LS-401P	For PNP output devices
Digital pressure sensor	DPS-401/402	For NPN output devices
Compact inductive proximity sensor	GA-311	For NPN output devices
Bank selection unit	FX-CH	For NPN input devices
	FX-CH-P	For PNP input devices

Note: The 2-output type can output the output 1 (OUT 1) only from **SC-MIL**. There is no connection for output 2 (OUT2).

I/O CIRCUIT AND WIRING DIAGRAMS

SC-MIL SC-MIL-S

Main unit
Separate unit

Pin layout diagram for MIL connector pins

Description	0V	+V	Signal 7	Signal 6	Signal 5	Signal 4	Signal 3	Signal 2	Signal 1	Signal 0
Pin Number	10	9	8	7	6	5	4	3	2	1

Mark on connector for pin number 20

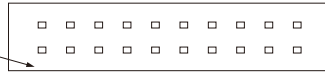

Pin Number	20	19	18	17	16	15	14	13	12	11
Description	0V	+V	Signal 15	Signal 14	Signal 13	Signal 12	Signal 11	Signal 10	Signal 9	Signal 8

- * The MIL connector pin layout is compatible with **SL-BMW** sensor block, which is utilized to simplify wiring and save space.
- * +V (pin No.10 and 20) and 0 V (pin No. 9 and 19) are connected inside the block.

SC-T1J

Connector input extension unit
For NPN output devices

Snap male connector pin position

Pin No.	SC-T1J
1	+V
2	GND
3	Input 1
4	Input 2 (Note 1)

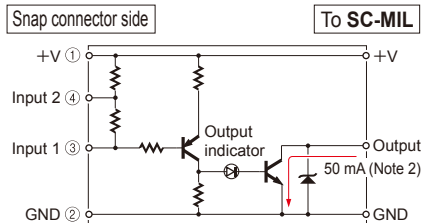

- Notes: 1) For DC 2-wire type input device
- Conditions
- Leak current : 1 mA or less (when the power is OFF)
 - Offset voltage : 3 V or less (when the power is ON)
 - The product of which the load current range contains 5 to 8 mA.
- 2) Residual voltage: 1 V or less (at 50 mA sink current)

SC-E1 SC-E81

e-CON 1-channel connector input extension unit
e-CON 8-channel connector input extension unit

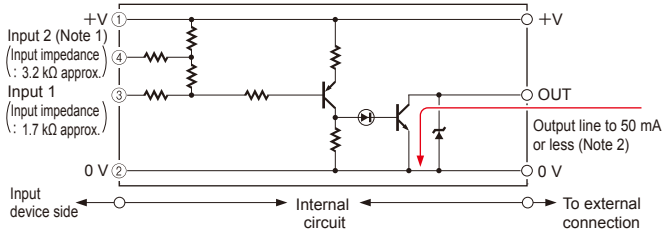

- Notes: 1) Only **SC-E1** can be used.
- For DC 2-wire type input device (24 V DC only)
- Leak current: 1 mA or less (when the power is OFF)
 - Offset voltage: 3 V or less (when the power is ON)
 - The product of which the load current range contains 5 to 8 mA.
- 2) Residual voltage: 1 V or less (at 50 mA sink current)

SC-T1J-P

Connector input extension unit
For PNP output devices

Snap male connector pin position

Pin No.	SC-T1J-P
1	+V
2	GND
3	Input 1
4	Input 2 (Note 1)

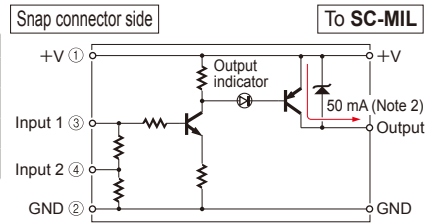

- Notes: 1) For DC 2-wire type input device
- Conditions
- Leak current: 1 mA or less (when the power is OFF)
 - Offset voltage: 3 V or less (when the power is ON)
 - The product of which the load current range contains 5 to 8 mA.
- 2) Residual voltage: 1 V or less (at 50 mA source current)

SC-E82

e-CON 8-channel connector input extension unit
(Without an input signal indicator)

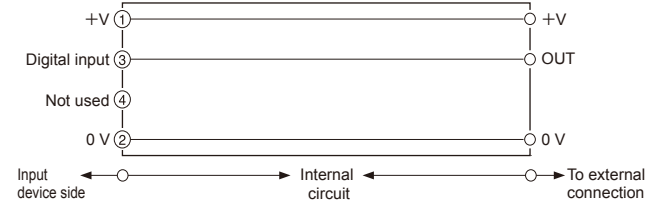

- Notes: 1) It depends on the power supply from **SC-MIL** or **SC-GU3-0□**.
- 2) When using a DC 2-wire input device, connect a device recommended load to the outside.

PRECAUTIONS FOR PROPER USE



- Never use this product in a device for personnel protection.
- In case of using devices for personnel protection, use products which meet laws and standards, such as OSHA, ANSI or IEC etc., for personnel protection applicable in each region or country.

- This product has been developed / produced for industrial use only.
- This product is suitable for indoor use only.
- Do not use during the initial transient time (0.5 sec.) after the power supply is switched on.
- This product is used as a device conforming to CE marking, depending on the connected device, it is recommended that a ferritecore is connected on the signal line of the connected device.
- When the units are used in a condition that the connector part of the unit located at the final end in cascade connection is exposed, there may be malfunction or electric shock. Therefore, make sure to stick the connector protection seal enclosed with **SC-MIL** or **SC-MIL-S** on the connector part of the unit at the final end.

DIMENSIONS (Unit : mm in)

The CAD data can be downloaded from our website.

SC-MIL Main unit

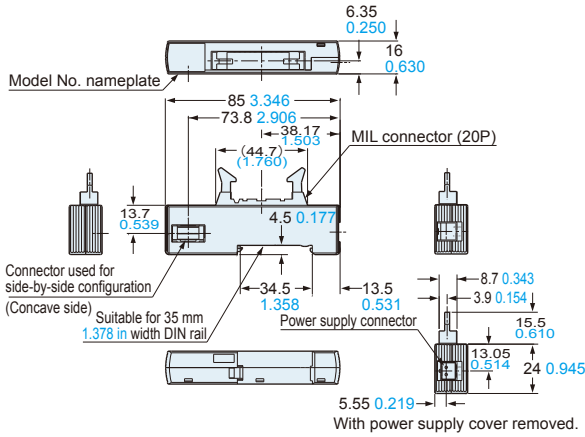

SC-MIL-S Separate unit

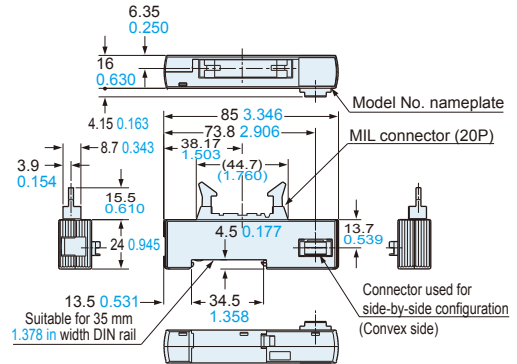

SC-T1J SC-T1J-P Connector input extension unit

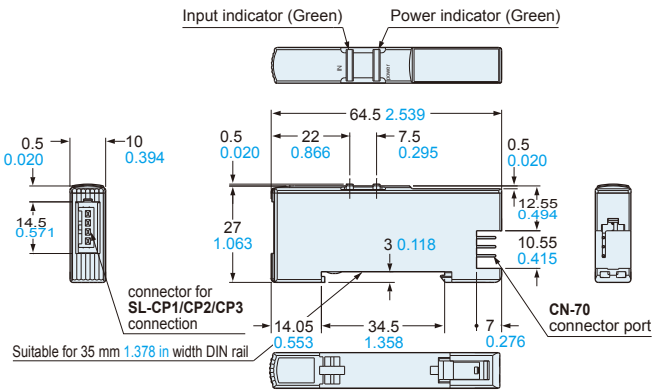

SC-E1 e-CON 1ch connector input extension unit

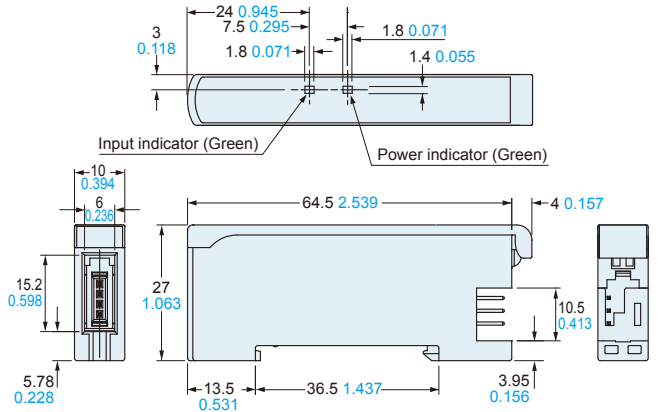

SC-E81 SC-E82 e-CON 8ch connector input extension unit

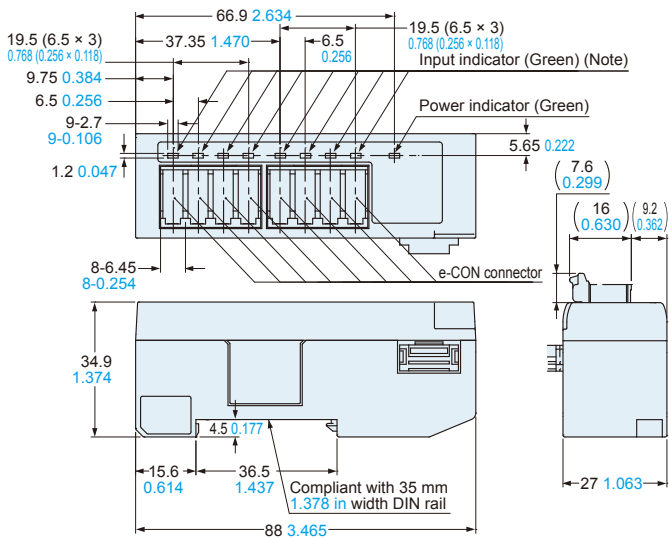

Note: SC-E82 is not equipped with an input indicator.

CN-70 Non-line connector

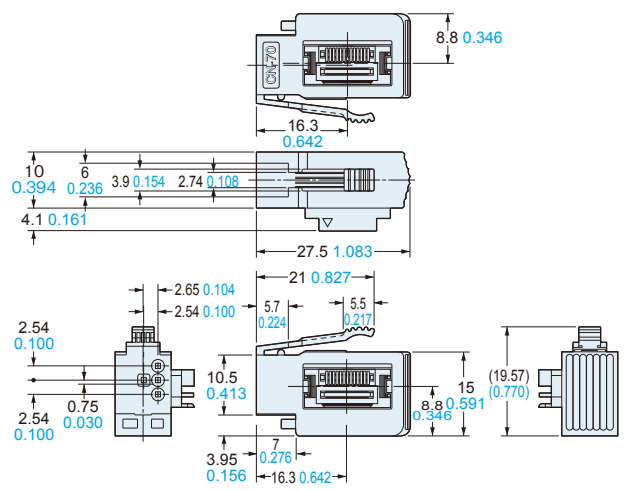

MS-DIN-E End plate

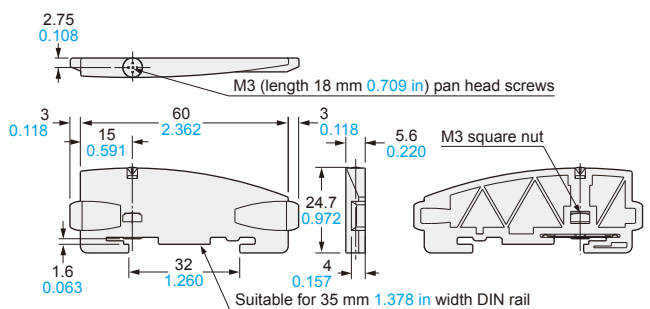

Material: Polycarbonate

Disclaimer

The applications described in the catalog are all intended for examples only. The purchase of our products described in the catalog shall not be regarded as granting of a license to use our products in the described applications. We do NOT warrant that we have obtained some intellectual properties, such as patent rights, with respect to such applications, or that the described applications may not infringe any intellectual property rights, such as patent rights, of a third party.

Panasonic
INDUSTRY

Panasonic Industry Co., Ltd.

Industrial Device Business Division
7-1-1, Morofuku, Daito-shi, Osaka 574-0044, Japan
industry.panasonic.com