

Automotive Relays
CA RELAYS

Product Catalog

**IN Your
Future**

CA RELAYS

Small Size, Light Weight Automotive Power Relays

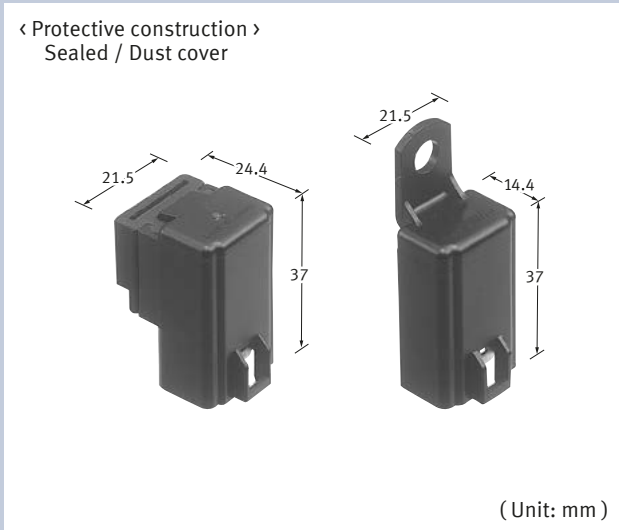

FEATURES

- Small size and light weight
- Since the terminal arrangement complies with JIS
- Low operating power (1.4 W) type is available (1 Form A, 1 Form B).

TYPICAL APPLICATIONS

- Motorcycles and automobiles
Motorcycle cell motors, car air conditioners, halogen lamps, etc.
- Agricultural equipment
- Battery equipped devices such as conveyance vehicles

ORDERING INFORMATION (PART NO. : Ordering part number for Japanese market)

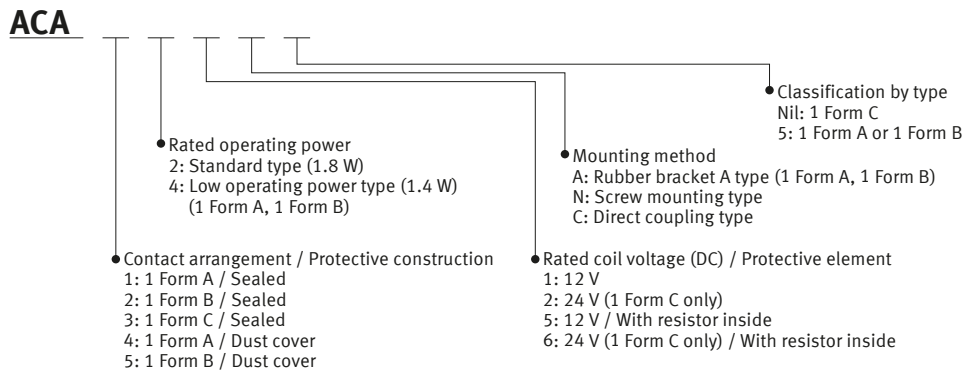

Note: Please contact our sales representative for 1 Form A or 1 Form B of 24 V DC type.

ORDERING INFORMATION (TYPE NO. : Ordering part number for non Japanese market)

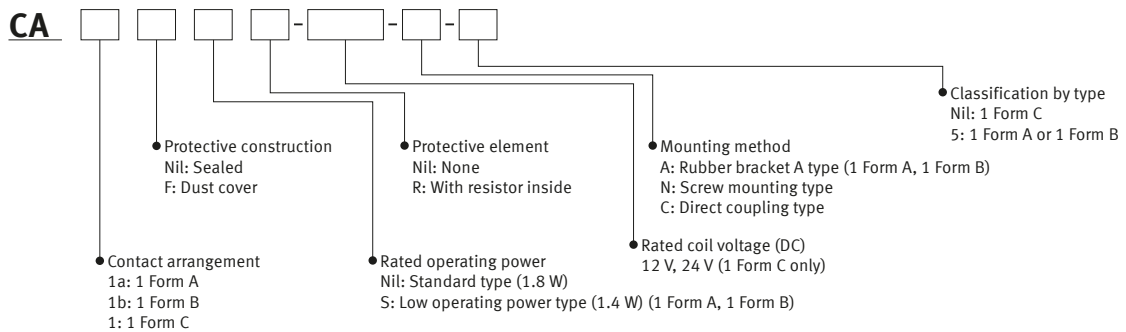

Automotive Relays CA RELAYS

TYPES

" Type No. " is ordering part number for non Japanese market. " Part No. " is ordering part number for Japanese market.

Contact arrangement	Mounting type	Rated coil voltage	Standard type (1.8 W)				Low operating power type (1.4 W)				Packing	
			Sealed		Dust cover		Sealed		Dust cover		Carton	Case
			Type No.	Part No.	Type No.	Part No.	Type No.	Part No.	Type No.	Part No.		
1 Form A	Rubber bracket A type	12 V DC	CA1a-12V-A-5	ACA12115	CA1aF-12V-A-5	ACA42115	CA1aS-12V-A-5	ACA14115	CA1aFS-12V-A-5	ACA44115	20 pcs.	200 pcs.
	Screw-mounting type		CA1a-12V-N-5	ACA12135	CA1aF-12V-N-5	ACA42135	CA1aS-12V-N-5	ACA14135	CA1aFS-12V-N-5	ACA44135		
	Direct coupling type		CA1a-12V-C-5	ACA12145	CA1aF-12V-C-5	ACA42145	CA1aS-12V-C-5	ACA14145	CA1aFS-12V-C-5	ACA44145		
1 Form B	Rubber bracket A type		CA1b-12V-A-5	ACA22115	CA1bF-12V-A-5	ACA52115	CA1bS-12V-A-5	ACA24115	CA1bFS-12V-A-5	ACA54115		
	Screw-mounting type		CA1b-12V-N-5	ACA22135	CA1bF-12V-N-5	ACA52135	CA1bS-12V-N-5	ACA24135	CA1bFS-12V-N-5	ACA54135		
	Direct coupling type		CA1b-12V-C-5	ACA22145	CA1bF-12V-C-5	ACA52145	CA1bS-12V-C-5	ACA24145	CA1bFS-12V-C-5	ACA54145		
1 Form C	Screw-mounting type	12 V DC	CA1-DC12V-N	ACA3213	-	-	-	-	-	-		
	Direct coupling type		CA1-DC12V-C	ACA3214	-	-	-	-	-	-		
	Screw-mounting type	24 V DC	CA1-DC24V-N	ACA3223	-	-	-	-	-	-		
	Direct coupling type		CA1-DC24V-C	ACA3224	-	-	-	-	-	-		

Note) Please use " CA**R-*.** " or CA**SR-*.** " with resistor inside type. (Asterisks " * " should be filled in from ORDERING INFORMATION.)

RATING

Coil data

1) No protective element

Contact arrangement	Rated coil voltage	Operate voltage (at 20 °C) (Initial)	Release voltage (at 20 °C) (Initial)	Rated operating current [±10 %] (at 20 °C)	Coil resistance [±10 %] (at 20 °C)	Rated operating power (at 20 °C)	Usable voltage range
1 Form A, 1 Form B (standard type)	12 V DC	Max. 8 V DC	0.6 to 6 V DC	150 mA	80 Ω	1.8 W	10 to 16 V DC
1 Form A, 1 Form B (low operating power type)				120 mA	100 Ω	1.4 W	
1 Form C	12 V DC	Max. 8 V DC	Min. 0.6 V DC	150 mA	80 Ω	1.8 W	10 to 15 V DC
	24 V DC	Max. 16 V DC	Min. 1.2 V DC	75 mA	320 Ω		20 to 30 V DC

2) With resistor inside

Contact arrangement	Rated coil voltage	Operate voltage (at 20 °C) (Initial)	Release voltage (at 20 °C) (Initial)	Rated operating current [±10 %] (at 20 °C)	Coil resistance [±10 %] (at 20 °C)	Rated operating power (at 20 °C)	Usable voltage range
1 Form A, 1 Form B (standard type)	12 V DC	Max. 8 V DC	0.6 to 6 V DC	160.9 mA	74.6 Ω	1.93 W	10 to 16 V DC
1 Form A, 1 Form B (low operating power type)				130.9 mA	91.7 Ω	1.57 W	
1 Form C	12 V DC	Max. 8 V DC	Min. 0.6 V DC	160.9 mA	74.6 Ω	1.93 W	10 to 15 V DC
	24 V DC	Max. 16 V DC	Min. 1.2 V DC	80 mA	299.6 Ω	1.92 W	20 to 30 V DC

Note) Other operate voltage types are also available. Please inquire our sales representative for details.

Automotive Relays CA RELAYS

■ Specifications

1) 12 V DC type

Item	Specifications			
	1 Form A	1 Form B	1 Form C	
Contact data	Contact arrangement	1 Form A	1 Form B	1 Form C
	Contact resistance (initial)	Max. 50 mΩ (typ. 3 mΩ) (By voltage drop 1 A 6 V DC)		
	Contact material	Ag alloy		
	Rated switching capacity (resistive)	20 A 12 V DC (1.4 W type) 30 A 12 V DC (1.8 W type)	20 A 12 V DC	
	Max. carrying current*1 (at coil applied voltage 14 V DC, at 80 °C)	20 A continuous (1.4 W type) 30 A for 1 min (1.8 W type)	20 A continuous	
	Min. switching load (resistive) *2	1 A 14 V DC (at 20 °C)		
	Contact voltage drop (after electrical life)	Max. 0.3 V [at 20 A 12 V DC (1.4 W type), 30 A 12 V DC (1.8 W type) carrying]	Max. 0.3 V (at 20 A 12 V DC carrying)	Max. 0.4 V (at 20 A 12 V DC carrying)
Insulated resistance (initial)	Min. 10 MΩ (at 500 V DC, Measurement at same location as " Dielectric strength " section.)			
Dielectric strength (initial)	Between open contacts	500 Vrms for 1 min (Detection current: 10 mA)		
	Between contacts and coil	500 Vrms for 1 min (Detection current: 10 mA)		
Time characteristics (initial)	Operate time (at rated voltage)	Max. 10 ms (at 20 °C, without contact bounce time)	Max. 10 ms (at 20 °C)	Max. 10 ms (at 20 °C, without contact bounce time)
	Release time (at rated voltage)	Max. 10 ms (at 20 °C) (without diode)	Max. 10 ms (at 20 °C, without contact bounce time)	Max. 10 ms (at 20 °C, without contact bounce time) (without diode)
Shock resistance	Functional	Min. 200 m/s ² (Half-wave pulse of sine wave: 11 ms, detection time: 10 μs)	Min. 100 m/s ² (Half-wave pulse of sine wave: 11 ms, detection time: 10 μs)	
	Destructive	Min. 1,000 m/s ² (Half-wave pulse of sine wave: 6 ms)		
Vibration resistance	Functional	Rubber bracket A type: 50 to 500 Hz, Min. 100 m/s ² , screw-mounting type, direct coupling type JIS D1601 Type 1, Class B, stage 45, [33 Hz, 45 m/s ²] (detection time: 10 μs)		
	Destructive	Rubber bracket A type: 50 to 500 Hz, Min. 100 m/s ² , screw-mounting type, direct coupling type JIS D1601 Type 1, Class B, stage 45, [33 Hz, 45 m/s ²] (Time of vibration for each direction; X, Y direction: 2 hours, Z direction: 4 hours)		
Expected life	Mechanical	Min. 10 ⁶ (at 120 times/min)		Min. 5 × 10 ⁵ (at 120 times/min)
	Electrical (at rated switching capacity)	Min. 10 ⁵ (operating frequency: 2 s ON, 2 s OFF) (1.4 W at 20 A) Min. 2 × 10 ⁴ (operating frequency: 2 s ON, 2 s OFF) (1.8 W type at 30 A)	Min. 10 ⁵ (operating frequency: 2 s ON, 2 s OFF)	
Conditions	Conditions for usage, transport and storage *3	Ambient temperature: -30 to +80 °C, Humidity: 5 to 85 % RH (Avoid icing and condensation)		
Water-proof standard	Sealed: JIS D 0203 S2, Dust cover: JIS D 0203 R2			
Weight	Rubber bracket A type: approx. 23 g, Screw-mounting and direct coupling types: approx. 19 g		approx. 31 g	

*1: Depends on connection conditions. Also, this does not guarantee repeated switching. We recommend that you confirm operation under actual conditions.

*2: This value can change due to the switching frequency, environmental conditions, and desired reliability level, therefore it is recommended to check this with the actual load.

*3: The upper operation ambient temperature limit is the maximum temperature that can satisfy the coil temperature rise value. For details, please refer to the " Automotive Relay Users Guide " .

Please inquire our sales representative if you will be using the relay in a high temperature atmosphere (110 °C) .

Automotive Relays CA RELAYS

2) 24 V DC type

Item		Specifications
Contact data	Contact arrangement	1 Form C
	Contact resistance (initial)	Max. 50 mΩ (typ. 3 mΩ) (By voltage drop 6 V DC 1 A)
	Contact material	Ag alloy
	Rated switching capacity (resistive)	10 A 24 V DC
	Max. carrying current* ¹	10 A continuous (at coil applied voltage 28 V DC, at 80 °C)
	Min. switching load (resistive) * ²	1 A 14 V DC (at 20 °C)
	Contact voltage drop	Max. 0.4 V (after electrical life, at 24 V DC 10 A carrying)
Insulation resistance (initial)		Min. 10 MΩ (at 500 V DC, Measured portion is the same as the case of dielectric strength.)
Dielectric strength (initial)	Between open contacts	500 V rms for 1 min (Detection current: 10 mA)
	Between contact and coil	500 V rms for 1 min (Detection current: 10 mA)
Time characteristics (initial)	Operate time (at rated voltage)	Max. 10 ms (at 20 °C, without contact bounce time)
	Release time (at rated voltage)	Max. 10 ms (at 20 °C, without contact bounce time) (without diode)
Shock resistance	Functional	Min. 100 m/s ² (Half-wave pulse of sine wave: 11 ms, detection time: 10 μs)
	Destructive	Min. 1,000 m/s ² (Half-wave pulse of sine wave: 6 ms)
Vibration resistance	Functional	JIS D1601 Type 1, Class B, stage 45, [33 Hz, 45 m/s ²] (Detection time: 10 μs)
	Destructive	JIS D1601 Type 1, Class B, stage 45, [33 Hz, 45 m/s ²] (Time of vibration for each direction; X, Y direction: 2 hours, Z direction: 4 hours)
Expected life	Mechanical	Min. 5 × 10 ⁵ (at 120 times/min)
	Electrical (at rated switching capacity)	Min. 10 ⁵ (operating frequency: 2 s ON, 2 s OFF)
Conditions	Conditions for usage, transport and storage* ³	Ambient temperature: -30 to +80 °C, Humidity: 5 to 85 % RH (Avoid icing and condensation)
Water-proof standard		JIS D 0203 S2
Weight		approx. 31 g

*1: Depends on connection conditions. Also, this does not guarantee repeated switching. We recommend that you confirm operation under actual conditions.

*2: This value can change due to the switching frequency, environmental conditions, and desired reliability level, therefore it is recommended to check this with the actual load.

*3: The upper operation ambient temperature limit is the maximum temperature that can satisfy the coil temperature rise value. For details, please refer to the "Automotive Relay Users Guide". Please inquire our sales representative if you will be using the relay in a high temperature atmosphere (110 °C).

■ Electrical life

1) Standard (1.8 W)

Contact arrangement	Rated coil voltage	Motor load	Halogen lamp load
1 Form A	12 V DC	Operating frequency 3 s ON, 15 s OFF 12 V DC inrush 150 A, steady 30 A, Min. 2 × 10 ⁴	-
1 Form B	12 V DC	Operating frequency 2 s ON, 2 s OFF 12 V DC inrush 60 A, steady 20 A, Min. 10 ⁵	Operating frequency 1 s ON, 14 s OFF 12 V DC inrush 100 A, steady 20 A, Min. 10 ⁵
1 Form C	12 V DC	Operating frequency 2 s ON, 2 s OFF 12 V DC inrush 100 A, steady 20 A, Min. 10 ⁵	Operating frequency 1 s ON, 14 s OFF 12 V DC inrush 100 A, steady 20 A, Min. 10 ⁵
	24 V DC	Operating frequency 2 s ON, 2 s OFF 24 V DC inrush 50 A, steady 10 A, Min. 10 ⁵	Operating frequency 1 s ON, 14 s OFF 24 V DC inrush 50 A, steady 6 A, Min. 10 ⁵

2) Low operating power (1.4 W)

Contact arrangement	Rated coil voltage	Motor load	Halogen lamp load
1 Form A	12 V DC	Operating frequency 2 s ON, 2 s OFF 12 V DC inrush 120 A, steady 20 A, Min. 10 ⁵	Operating frequency 1 s ON, 14 s OFF 12 V DC inrush 100 A, steady 20 A, Min. 10 ⁵
1 Form B	12 V DC	Operating frequency 2 s ON, 2 s OFF 12 V DC inrush 60 A, steady 20 A, Min. 10 ⁵	Operating frequency 1 s ON, 14 s OFF 12 V DC inrush 100 A, steady 20 A, Min. 10 ⁵

Automotive Relays CA RELAYS

REFERENCE DATA

1. Coil temperature rise

Samples: CA1aS-12V-N-5, 5 pcs.
 Measured portion: Inside the coil
 Carrying current: 20 A
 Ambient temperature: Room temperature, 80°C

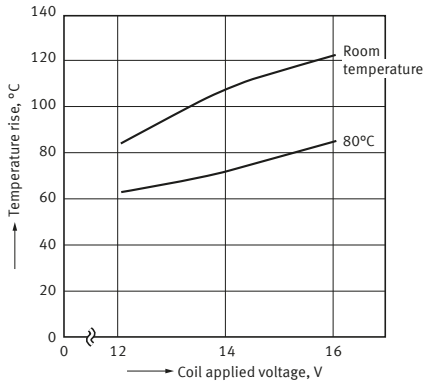

2. Ambient temperature and usable voltage range

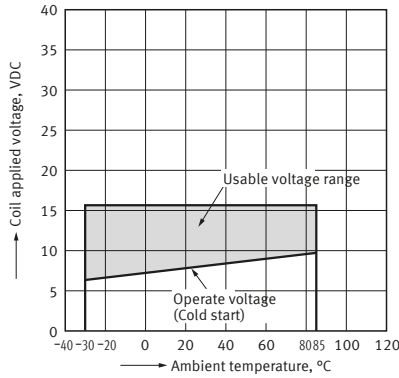

3. Ambient temperature characteristics (Cold start)

Samples: CA1bS-12V-N-5

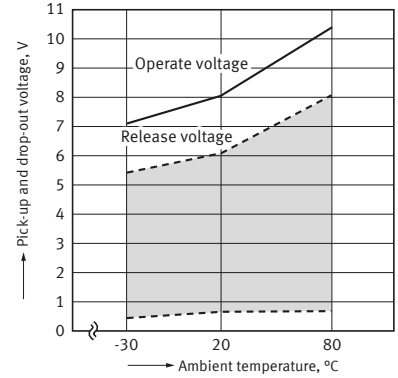

4. Distribution of operate and release voltage

Quantity: 50 pcs.

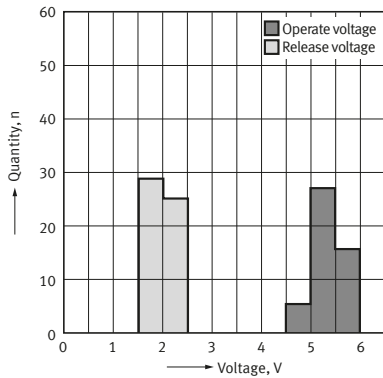

5. Distribution of operate and release time

Sample: CA1a-12V-N-5, 10 pcs.

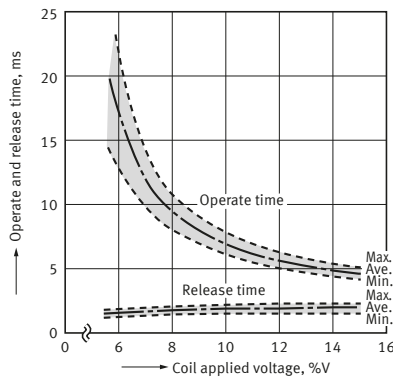

Automotive Relays CA RELAYS

6. Electrical life test (Motor load)

Sample: CA1a-12V-C, 3 pcs.
 Load: Inrush current: 63 A, steady current: 23 A
 Blower fan motor actual load (motor free)
 Operating frequency: ON 2 s, OFF 2 s
 Ambient temperature: Room temperature

Change of operate and release voltage

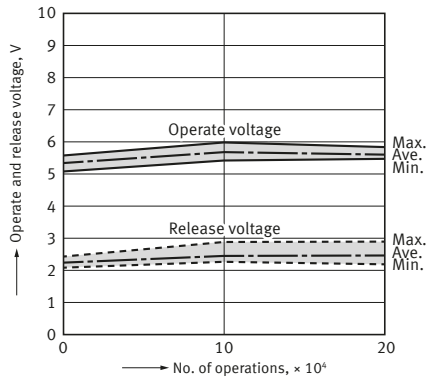

Change of contact resistance

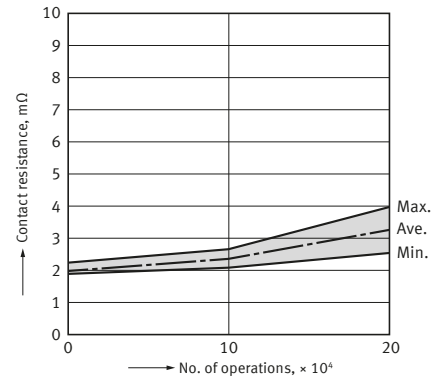

Load current waveform
 Load: Inrush current: 63 A, steady current: 23 A,

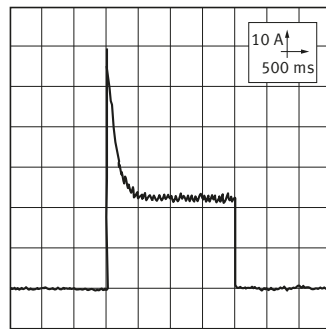

DIMENSIONS (Unit: mm)

CAD The CAD data of the products with a " CAD " mark can be downloaded from our Website.

■ 1 Form A / 1 Form B Rubber bracket A type

CAD



External dimensions

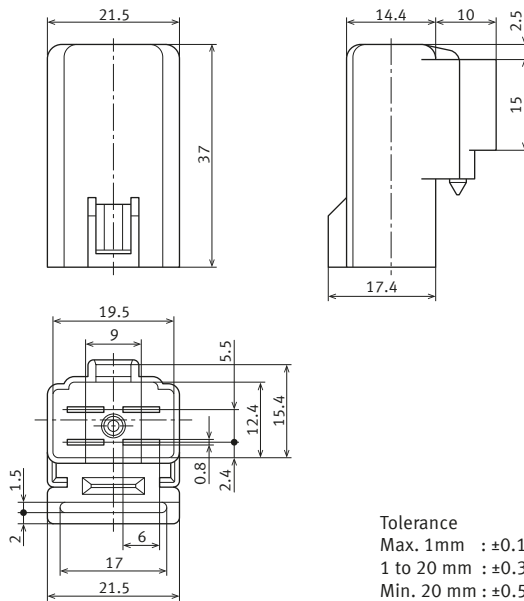

Tolerance
 Max. 1mm : ±0.1
 1 to 20 mm : ±0.3
 Min. 20 mm : ±0.5

Schematic (BOTTOM VIEW)

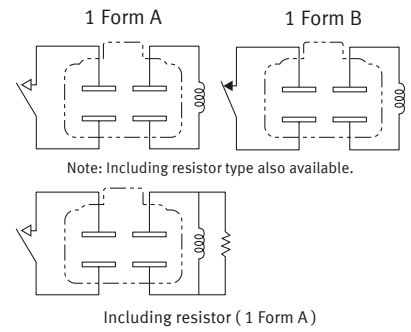

Automotive Relays CA RELAYS

■ 1 Form A / 1 Form B Screw-mounting type

CAD



External dimensions

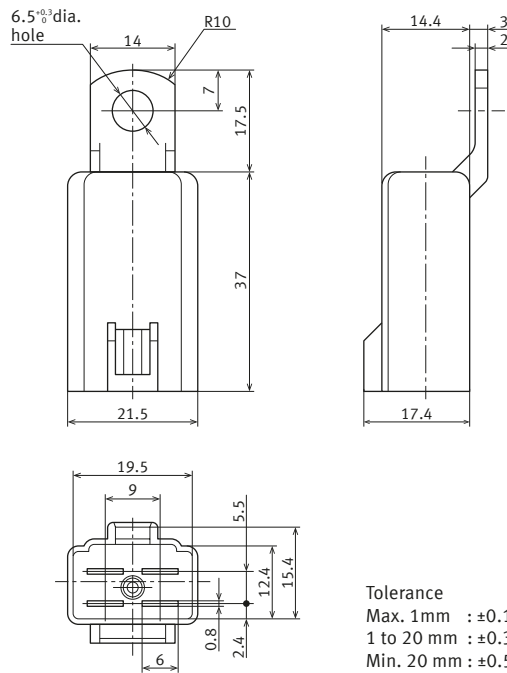

Tolerance
 Max. 1mm : ±0.1
 1 to 20 mm : ±0.3
 Min. 20 mm : ±0.5

Schematic
 (BOTTOM VIEW)

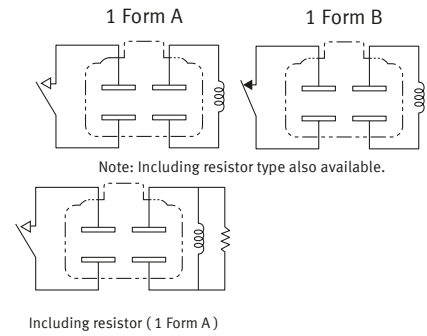

■ 1 Form A / 1 Form B Direct coupling type

CAD



External dimensions

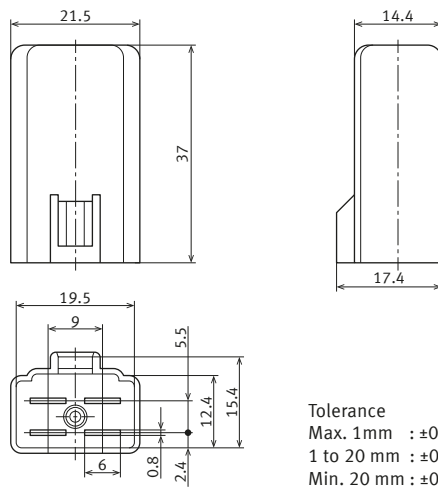

Tolerance
 Max. 1mm : ±0.1
 1 to 20 mm : ±0.3
 Min. 20 mm : ±0.5

Schematic
 (BOTTOM VIEW)

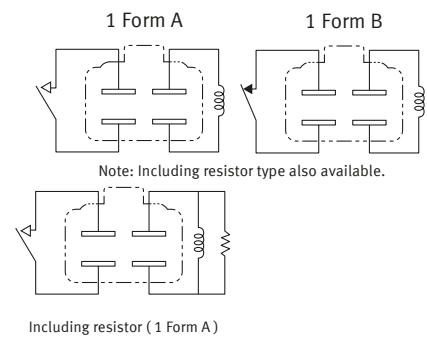

Automotive Relays CA RELAYS

■ 1 Form C Screw-mounting type

CAD



External dimensions

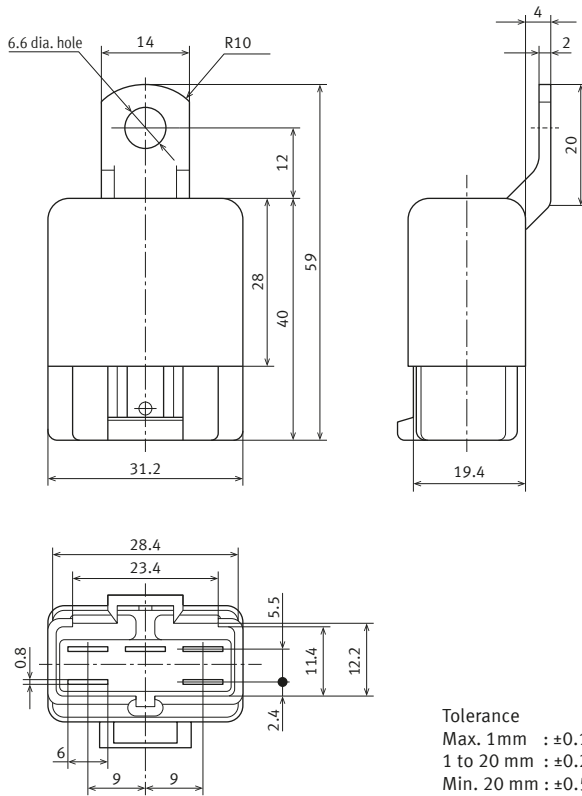

Schematic
(BOTTOM VIEW)

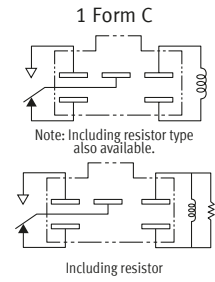

■ 1 Form C Direct coupling type

CAD



External dimensions

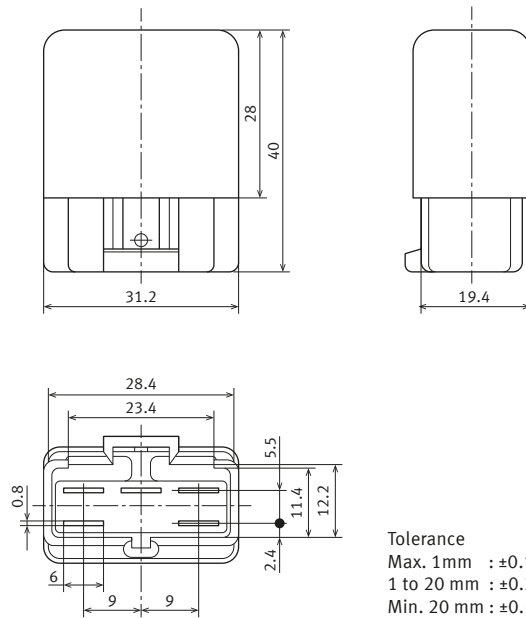

Schematic
(BOTTOM VIEW)

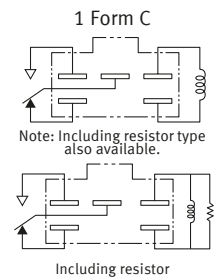

GUIDELINES FOR USAGE

■ For general cautions for use, please refer to the "Automotive Relay Users Guide".

Please refer to "the latest product specifications" when designing your product.
 • Requests to customers:
<https://industry.panasonic.com/global/en/salespolicies>

■ Global Sales Network Information: industry.panasonic.com/global/en/salesnetwork/globalnetwork

Panasonic
INDUSTRY

Panasonic Industry Co., Ltd.

Electromechanical Control Business Division

■ 1006, Oaza Kadoma, Kadoma-shi, Osaka 571-8506, Japan
industry.panasonic.com