

Power Relays (Over 2 A)
NC RELAYS

Product Catalog

**IN Your
Future**

NC RELAYS

Transistor drive, 2 Form C/4 Form C, 5 A Slim power relays

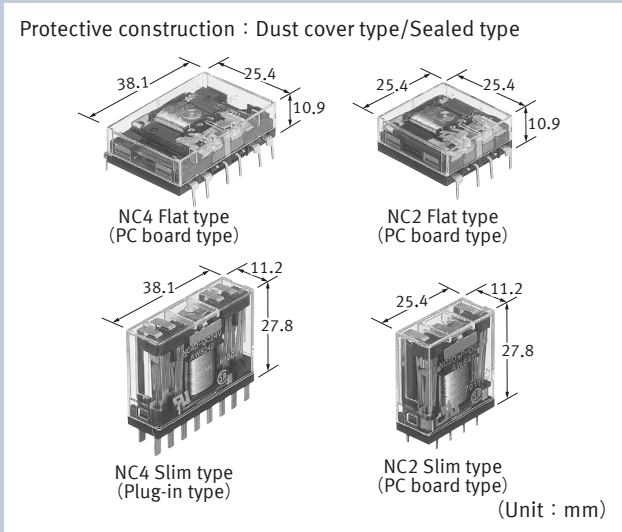

FEATURES

- Flat type: profile 10.9 mm
Slim type: width 11.2 mm
- Twin (bifurcated) contact
- Plug-in terminal/PC board terminal
- Sockets and terminal sockets are available

TYPICAL APPLICATIONS

- Electric power equipment
- Industrial equipment
- Measuring devices

ORDERING INFORMATION (PART NO. : Ordering part number for Japanese market)

AW 8

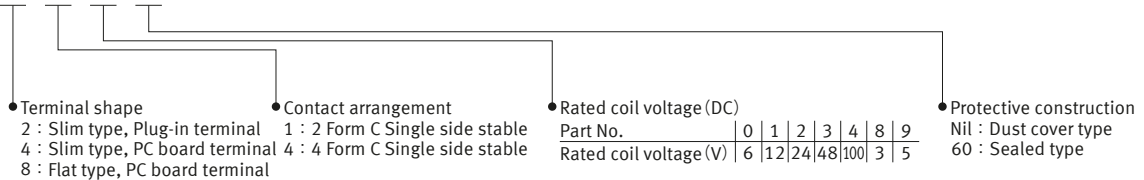

ORDERING INFORMATION (TYPE NO. : Ordering part number for non Japanese market)

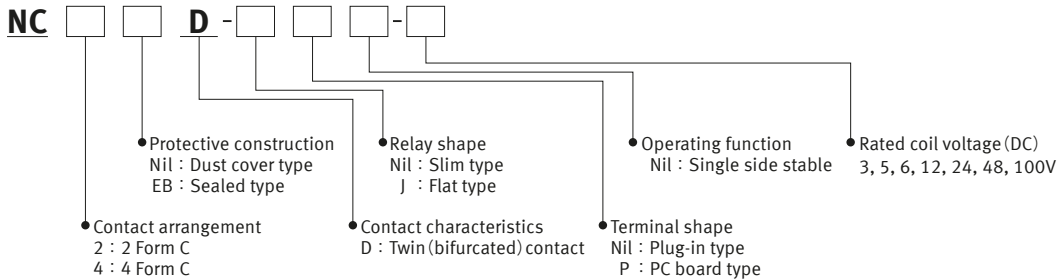

Power Relays (Over 2 A) NC RELAYS

TYPES

" Type No. " is ordering part number for non Japanese market. " Part No. " is ordering part number for Japanese market.

■ Dust cover type

● Flat type

Contact arrangement	Rated coil voltage	PC board terminal		Standard packing	
		Type No.	Part No.	Inner carton	Outer carton
2 Form C	3 V DC	NC2D-JP-DC3V	AW8818	20 pcs.	200 pcs.
	5 V DC	NC2D-JP-DC5V	AW8819		
	6 V DC	NC2D-JP-DC6V	AW8810		
	12 V DC	NC2D-JP-DC12V	AW8811		
	24 V DC	NC2D-JP-DC24V	AW8812		
	48 V DC	NC2D-JP-DC48V	AW8813		
	100 V DC	NC2D-JP-DC100V	AW8814		
4 Form C	3 V DC	NC4D-JP-DC3V	AW8848		
	5 V DC	NC4D-JP-DC5V	AW8849		
	6 V DC	NC4D-JP-DC6V	AW8840		
	12 V DC	NC4D-JP-DC12V	AW8841		
	24 V DC	NC4D-JP-DC24V	AW8842		
	48 V DC	NC4D-JP-DC48V	AW8843		
	100 V DC	NC4D-JP-DC100V	AW8844		

● Slim type

Contact arrangement	Rated coil voltage	Plug-in terminal		PC board terminal		Standard packing	
		Type No.	Part No.	Type No.	Part No.	Inner carton	Outer carton
2 Form C	3 V DC	NC2D-DC3V	AW8218	NC2D-P-DC3V	AW8418	20 pcs.	200 pcs.
	5 V DC	NC2D-DC5V	AW8219	NC2D-P-DC5V	AW8419		
	6 V DC	NC2D-DC6V	AW8210	NC2D-P-DC6V	AW8410		
	12 V DC	NC2D-DC12V	AW8211	NC2D-P-DC12V	AW8411		
	24 V DC	NC2D-DC24V	AW8212	NC2D-P-DC24V	AW8412		
	48 V DC	NC2D-DC48V	AW8213	NC2D-P-DC48V	AW8413		
	100 V DC	NC2D-DC100V	AW8214	NC2D-P-DC100V	AW8414		
4 Form C	3 V DC	NC4D-DC3V	AW8248	NC4D-P-DC3V	AW8448		
	5 V DC	NC4D-DC5V	AW8249	NC4D-P-DC5V	AW8449		
	6 V DC	NC4D-DC6V	AW8240	NC4D-P-DC6V	AW8440		
	12 V DC	NC4D-DC12V	AW8241	NC4D-P-DC12V	AW8441		
	24 V DC	NC4D-DC24V	AW8242	NC4D-P-DC24V	AW8442		
	48 V DC	NC4D-DC48V	AW8243	NC4D-P-DC48V	AW8443		
	100 V DC	NC4D-DC100V	AW8244	NC4D-P-DC100V	AW8444		

■ Sealed type

● Flat type

Contact arrangement	Rated coil voltage	PC board terminal		Standard packing	
		Type No.	Part No.	Inner carton	Outer carton
2 Form C	3 V DC	NC2EBD-JP-DC3V	AW881860	20 pcs.	200 pcs.
	5 V DC	NC2EBD-JP-DC5V	AW881960		
	6 V DC	NC2EBD-JP-DC6V	AW881060		
	12 V DC	NC2EBD-JP-DC12V	AW881160		
	24 V DC	NC2EBD-JP-DC24V	AW881260		
	48 V DC	NC2EBD-JP-DC48V	AW881360		
	100 V DC	NC2EBD-JP-DC100V	AW881460		
4 Form C	3 V DC	NC4EBD-JP-DC3V	AW884860		
	5 V DC	NC4EBD-JP-DC5V	AW884960		
	6 V DC	NC4EBD-JP-DC6V	AW884060		
	12 V DC	NC4EBD-JP-DC12V	AW884160		
	24 V DC	NC4EBD-JP-DC24V	AW884260		
	48 V DC	NC4EBD-JP-DC48V	AW884360		
	100 V DC	NC4EBD-JP-DC100V	AW884460		

Power Relays (Over 2 A) NC RELAYS

● Slim type

Contact arrangement	Rated coil voltage	Plug-in terminal		PC board terminal		Standard packing	
		Type No.	Part No.	Type No.	Part No.	Inner carton	Outer carton
2 Form C	3 V DC	NC2EBD-DC3V	AW821860	NC2EBD-P-DC3V	AW841860	20 pcs.	200 pcs.
	5 V DC	NC2EBD-DC5V	AW821960	NC2EBD-P-DC5V	AW841960		
	6 V DC	NC2EBD-DC6V	AW821060	NC2EBD-P-DC6V	AW841060		
	12 V DC	NC2EBD-DC12V	AW821160	NC2EBD-P-DC12V	AW841160		
	24 V DC	NC2EBD-DC24V	AW821260	NC2EBD-P-DC24V	AW841260		
	48 V DC	NC2EBD-DC48V	AW821360	NC2EBD-P-DC48V	AW841360		
	100 V DC	NC2EBD-DC100V	AW821460	NC2EBD-P-DC100V	AW841460		
4 Form C	3 V DC	NC4EBD-DC3V	AW824860	NC4EBD-P-DC3V	AW844860		
	5 V DC	NC4EBD-DC5V	AW824960	NC4EBD-P-DC5V	AW844960		
	6 V DC	NC4EBD-DC6V	AW824060	NC4EBD-P-DC6V	AW844060		
	12 V DC	NC4EBD-DC12V	AW824160	NC4EBD-P-DC12V	AW844160		
	24 V DC	NC4EBD-DC24V	AW824260	NC4EBD-P-DC24V	AW844260		
	48 V DC	NC4EBD-DC48V	AW824360	NC4EBD-P-DC48V	AW844360		
	100 V DC	NC4EBD-DC100V	AW824460	NC4EBD-P-DC100V	AW844460		

For the sockets, please refer to the "Sockets/DIN terminal sockets".

RATING

■ Coil data

- Operating characteristics such as "Operate voltage" and "Release voltage" are influenced by mounting conditions or ambient temperature, etc.
Therefore, please use the relay within $\pm 5\%$ of rated coil voltage.
- "Initial" means the condition of products at the time of delivery.

Contact arrangement	Rated coil voltage	Operate voltage*1 (at 20 °C)	Release voltage*1 (at 20 °C)	Rated operating current ($\pm 10\%$, at 20 °C)	Coil resistance ($\pm 10\%$, at 20 °C)	Rated operating power	Max. allowable voltage (at 50 °C) *2
2 Form C	3 V DC	Max. 80 % V of rated coil voltage (Initial)	Min. 10 % V of rated coil voltage (Initial)	120 mA	25 Ω	360 mW	135 % V of rated coil voltage
	5 V DC			72 mA	69.4 Ω		
	6 V DC			60 mA	100 Ω		
	12 V DC			30 mA	400 Ω		
	24 V DC			15 mA	1,600 Ω		
	48 V DC			7.5 mA	6,400 Ω		
	100 V DC			7.4 mA	13,500 Ω	740 mW	
4 Form C	3 V DC	Max. 80 % V of rated coil voltage (Initial)	Min. 10 % V of rated coil voltage (Initial)	240 mA	12.5 Ω	720 mW	110 % V of rated coil voltage
	5 V DC			144 mA	34.7 Ω		
	6 V DC			120 mA	50 Ω		
	12 V DC			60 mA	200 Ω		
	24 V DC			30 mA	800 Ω		
	48 V DC			15 mA	3,200 Ω		
	100 V DC			7.4 mA	13,500 Ω	740 mW	

*1: Square, pulse drive

*2: At 20°C (Sealed type)

Power Relays (Over 2 A) NC RELAYS

■ Specifications

Item		Specifications	
Contact data	Contact arrangement	2 Form C	4 Form C
	Contact resistance (initial)	Max. 50 mΩ (by voltage drop 6 V DC 1 A)	
	Contact material	Au-clad, AgNi type	
	Contact rating (resistive)	Dust cover: 5 A 250 V AC, 5 A 30 V DC Sealed : 3 A 250 V AC, 5 A 30 V DC	Dust cover: 4 A 250 V AC, 5 A 30 V DC Sealed : 2 A 250 V AC, 5 A 30 V DC
	Max. switching power (resistive)	Dust cover: 1,250 VA, 150 W Sealed : 750 VA, 150 W	Dust cover: 1,000 VA, 150 W Sealed : 500 VA, 150 W
	Max. switching voltage	250 V AC, 220 V DC	
	Max. switching current	Dust cover: 5 A (AC, DC) Sealed : 3 A (AC), 5 A (DC)	Dust cover: 4 A (AC), 5 A (DC) Sealed : 2 A (AC), 5 A (DC)
	Min. switching load (reference value) ^{*1}	100 μA 1 V DC	
Insulation resistance (initial)		Min. 100 MΩ (at 500 V DC, Measured portion is the same as the case of dielectric strength.)	
Dielectric strength (initial)	Between open contacts	1,000 Vrms for 1 min (detection current: 10 mA)	
	Between contact sets	1,000 Vrms for 1 min (detection current: 10 mA)	
	Between contact and coil	2,000 Vrms for 1 min (detection current: 10 mA)	
Time characteristics (initial)	Operate time	Max. 20 ms at rated coil voltage (at 20 °C, without bounce)	
	Release time	Max. 10 ms at rated coil voltage (at 20 °C, without bounce, without diode)	
Shock resistance	Functional	98 m/s ² (half-sine shock pulse: 11 ms, detection time: 10 μs)	
	Destructive	980 m/s ² (half-sine shock pulse: 6 ms)	
Vibration resistance	Functional	10 to 55 Hz (at double amplitude of 1 mm, detection time: 10 μs)	
	Destructive	10 to 55 Hz (at double amplitude of 2 mm)	
Expected life	Mechanical life	Min. 50 × 10 ⁶ ope. (switching frequency: at 180 times/min)	
Conditions	Conditions for usage, transport and storage ^{*2}	Ambient temperature: -40 to +70 °C (Max. 48 V DC), -40 to +55 °C (Min. 100 V DC) Humidity: 5 to 85 % RH (Avoid icing and condensation)	Ambient temperature: -40 to +55 °C Humidity: 5 to 85 % RH (Avoid icing and condensation)
Unit weight		Approx. 16 g	Slim type: Approx. 19 g Flat type : Approx. 18 g

*1: This value can change due to the switching frequency, environmental conditions, and desired reliability level, therefore it is recommended to check this with the actual load.

*2: For ambient temperature, please read " GUIDELINES FOR RELAY USAGE ".

■ Expected electrical life

Conditions: Resistive load, switching frequency at 20 times/min

Type	Switching capacity	Number of operations	
2 Form C	Dust cover	5 A 30 V DC	Min. 500 × 10 ³ ope.
		5 A 250 V AC	Min. 100 × 10 ³ ope.
	Sealed	5 A 30 V DC	Min. 500 × 10 ³ ope.
		3 A 250 V AC	Min. 100 × 10 ³ ope.
4 Form C	Dust cover	5 A 30 V DC	Min. 500 × 10 ³ ope.
		4 A 250 V AC	Min. 100 × 10 ³ ope.
	Sealed	5 A 30 V DC	Min. 500 × 10 ³ ope.
		2 A 250 V AC	Min. 100 × 10 ³ ope.

Power Relays (Over 2 A) NC RELAYS

REFERENCE DATA

1-1. Switching life curve (2 Form C, 4 Form C)

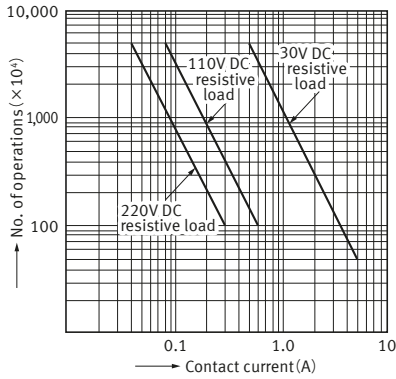

1-2. Switching life curve (2 Form C)

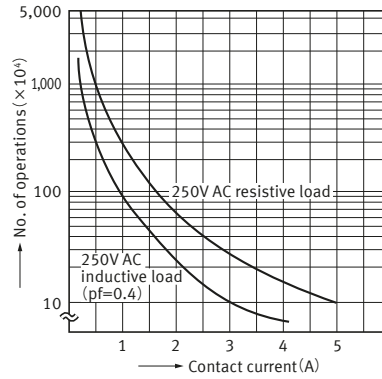

1-3. Switching life curve (4 Form C)

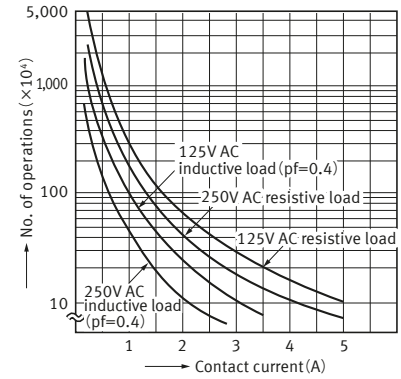

2. Coil temperature characteristics

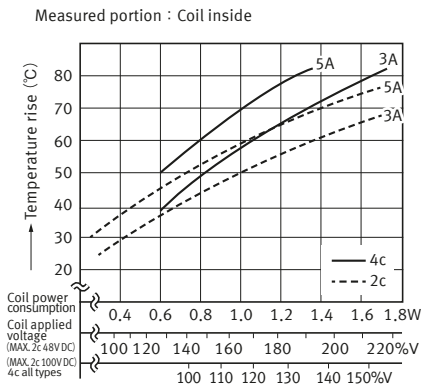

3-1. Ambient temperature characteristics (2 Form C)

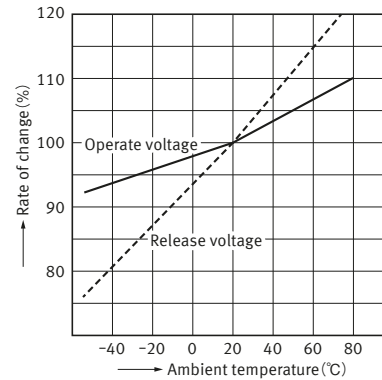

3-2. Ambient temperature characteristics (4 Form C)

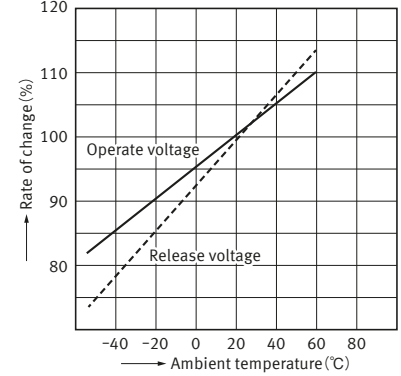

4. Operate time

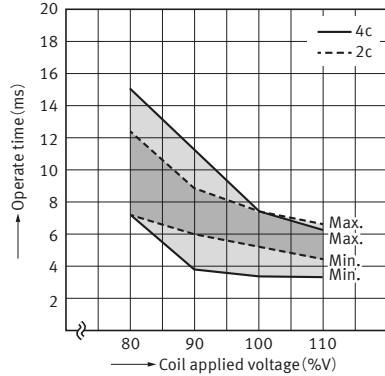

5. Release time

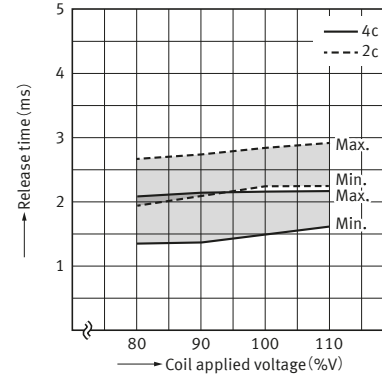

6-1. Ambient temperature vs Max. applied voltage (2 Form C: 3 to 48 V DC type)

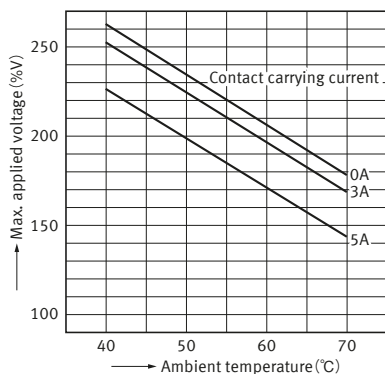

6-2. Ambient temperature vs Max. applied voltage (2 Form C: 100 V DC type, 4 Form C)

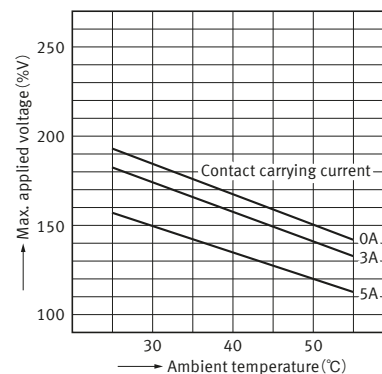

Power Relays (Over 2 A) NC RELAYS

DIMENSIONS (Unit: mm)

CAD The CAD data of the products with a " CAD " mark can be downloaded from our Website.

■ Dust cover: Flat type

● PC board terminal: 2 Form C

CAD

External dimensions

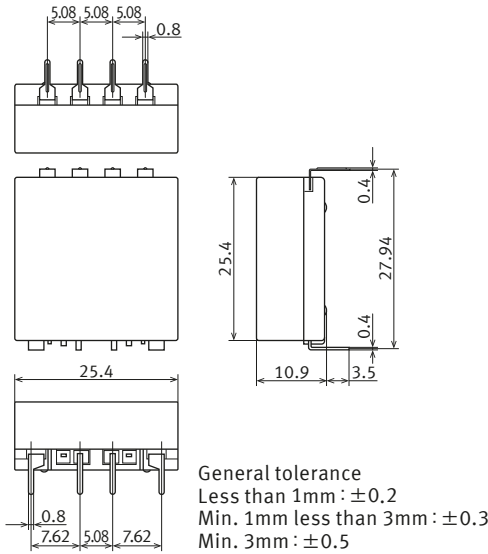
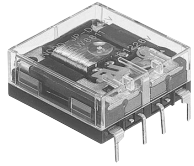

Recommended
PC board pattern
(BOTTOM VIEW)

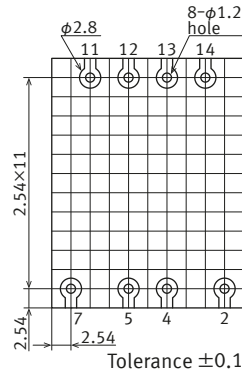

Schematic
(TOP VIEW)
(De-energize)

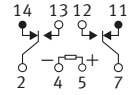

● PC board terminal: 4 Form C

CAD

External dimensions

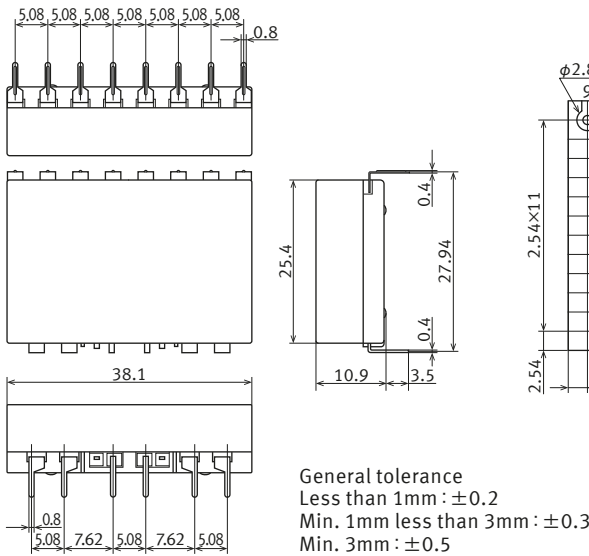
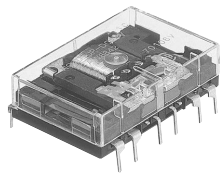

Recommended
PC board pattern
(BOTTOM VIEW)

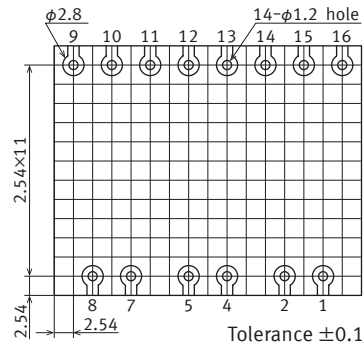

Schematic
(TOP VIEW)
(De-energize)

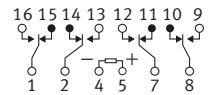

Power Relays (Over 2 A) NC RELAYS

- Dust cover: Slim type
- Plug-in terminal: 2 Form C

CAD



External dimensions

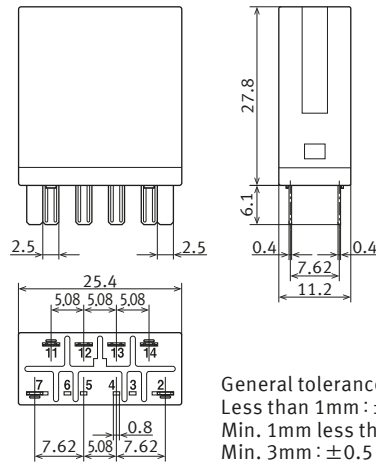

General tolerance
 Less than 1mm : ± 0.2
 Min. 1mm less than 3mm : ± 0.3
 Min. 3mm : ± 0.5

Schematic
 (BOTTOM VIEW)
 (De-energize)

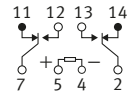

- Plug-in terminal: 4 Form C

CAD

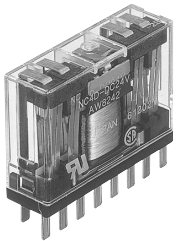

External dimensions

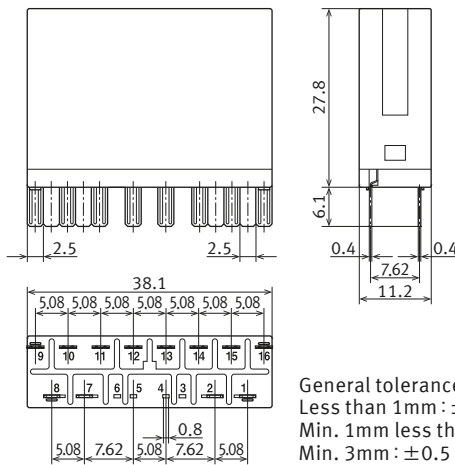

General tolerance
 Less than 1mm : ± 0.2
 Min. 1mm less than 3mm : ± 0.3
 Min. 3mm : ± 0.5

Schematic
 (BOTTOM VIEW)
 (De-energize)

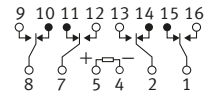

- PC board terminal: 2 Form C

CAD



External dimensions

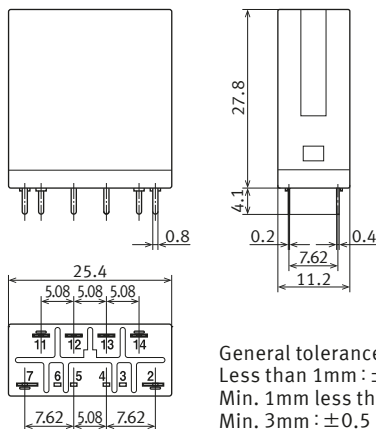

General tolerance
 Less than 1mm : ± 0.2
 Min. 1mm less than 3mm : ± 0.3
 Min. 3mm : ± 0.5

Recommended
 PC board pattern
 (BOTTOM VIEW)

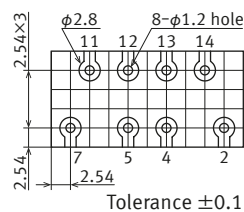

Tolerance ± 0.1

Schematic
 (BOTTOM VIEW)
 (De-energize)

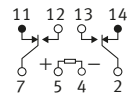

Power Relays (Over 2 A) NC RELAYS

● PC board terminal: 4 Form C

CAD

External dimensions

Recommended
PC board pattern
(BOTTOM VIEW)

Schematic
(BOTTOM VIEW)
(De-energize)

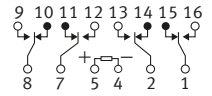
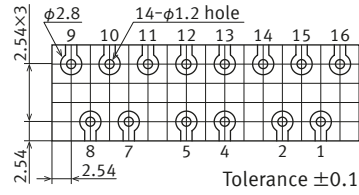
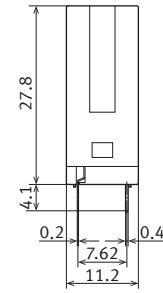
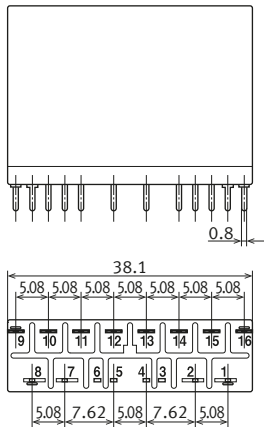
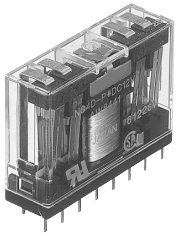

General tolerance
Less than 1mm : ± 0.2
Min. 1mm less than 3mm : ± 0.3
Min. 3mm : ± 0.5

■ Sealed: Flat type

● PC board terminal: 2 Form C

CAD

External dimensions

Recommended
PC board pattern
(BOTTOM VIEW)

Schematic
(TOP VIEW)
(De-energize)

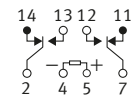
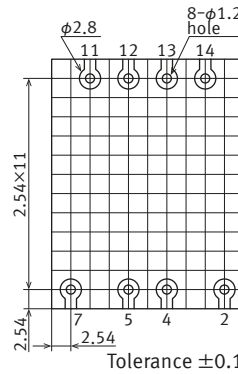
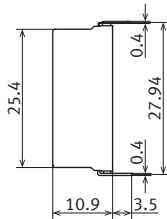
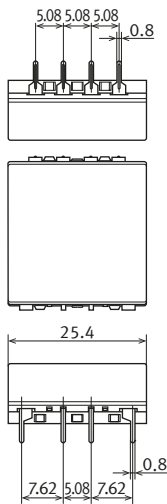
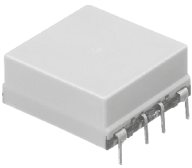

General tolerance
Less than 1mm : ± 0.2
Min. 1mm less than 3mm : ± 0.3
Min. 3mm : ± 0.5

● PC board terminal: 4 Form C

CAD

External dimensions

Recommended
PC board pattern
(BOTTOM VIEW)

Schematic
(TOP VIEW)
(De-energize)

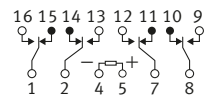
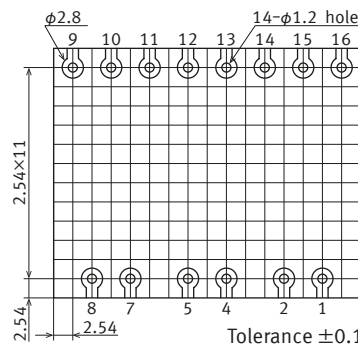
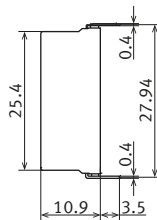
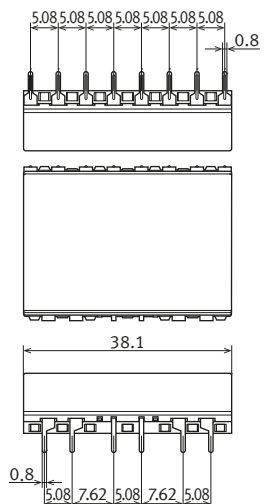
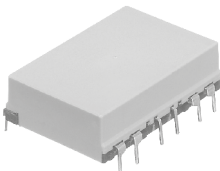

General tolerance
Less than 1mm : ± 0.2
Min. 1mm less than 3mm : ± 0.3
Min. 3mm : ± 0.5

Power Relays (Over 2 A) NC RELAYS

- Sealed: Slim type
- Plug-in terminal: 2 Form C

CAD



External dimensions

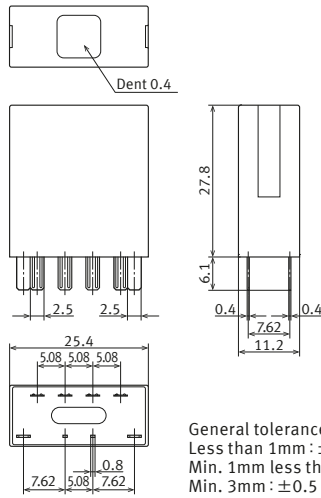

General tolerance
 Less than 1mm : ± 0.2
 Min. 1mm less than 3mm : ± 0.3
 Min. 3mm : ± 0.5

Schematic
 (BOTTOM VIEW)
 (De-energize)

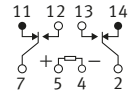

- Plug-in terminal: 4 Form C

CAD

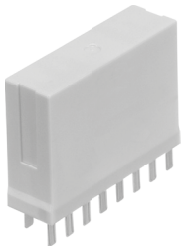

External dimensions

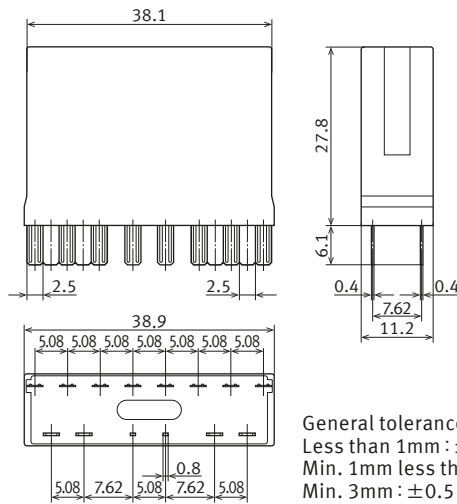

General tolerance
 Less than 1mm : ± 0.2
 Min. 1mm less than 3mm : ± 0.3
 Min. 3mm : ± 0.5

Schematic
 (BOTTOM VIEW)
 (De-energize)

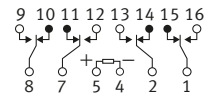

- PC board terminal: 2 Form C

CAD



External dimensions

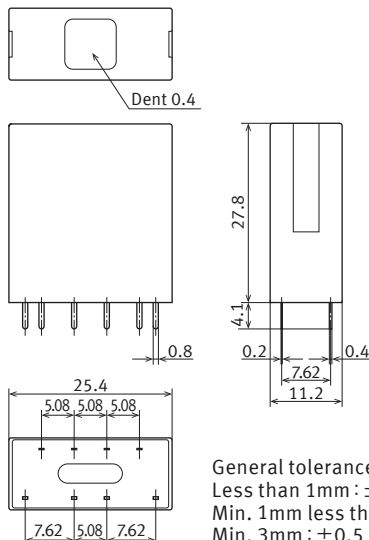

General tolerance
 Less than 1mm : ± 0.2
 Min. 1mm less than 3mm : ± 0.3
 Min. 3mm : ± 0.5

Recommended
 PC board pattern
 (BOTTOM VIEW)

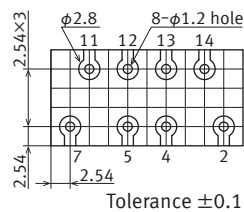

Schematic
 (BOTTOM VIEW)
 (De-energize)

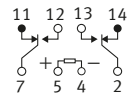

Power Relays (Over 2 A) NC RELAYS

● PC board terminal: 4 Form C

CAD

External dimensions

Recommended PC board pattern (BOTTOM VIEW)

Schematic (BOTTOM VIEW) (De-energize)

General tolerance
 Less than 1mm : ±0.2
 Min. 1mm less than 3mm : ±0.3
 Min. 3mm : ±0.5

SAFETY STANDARDS

Each standard may be updated at any time, so please check our Website for the latest information.

■ UL (Approved)

● Dust cover

2 Form C

File No.	Contact rating	Operations
E43028	5 A 250 V AC	100 × 10 ³
	5 A 30 V DC	100 × 10 ³
	1/10 HP 125, 250 V AC	—

4 Form C

File No.	Contact rating	Operations
E43028	5 A 30 V DC	100 × 10 ³
	4 A 250 V AC	100 × 10 ³
	1/10 HP 125, 250 V AC	—

■ CSA (Approved)

● Dust cover

2 Form C

File No.	Contact rating	Operations
1440474	5 A 250 V AC	100 × 10 ³
	5 A 30 V DC	100 × 10 ³
	1/10 HP 125, 250 V AC	—

4 Form C

File No.	Contact rating	Operations
1440474	5 A 30 V DC	100 × 10 ³
	4 A 250 V AC	100 × 10 ³
	1/10 HP 125, 250 V AC	—

● Sealed

2 Form C

File No.	Contact rating	Operations
E43028	5 A 30 V DC	100 × 10 ³
	3 A 250 V AC	100 × 10 ³
	1/10 HP 125, 250 V AC	—

4 Form C

File No.	Contact rating	Operations
E43028	5 A 30 V DC	100 × 10 ³
	2 A 250 V AC	100 × 10 ³
	1/10 HP 125, 250 V AC	—

● Sealed

2 Form C

File No.	Contact rating	Operations
1440474	5 A 30 V DC	100 × 10 ³
	3 A 250 V AC	100 × 10 ³
	1/10 HP 125, 250 V AC	—

4 Form C

File No.	Contact rating	Operations
1440474	5 A 30 V DC	100 × 10 ³
	2 A 250 V AC	100 × 10 ³
	1/10 HP 125, 250 V AC	—

GUIDELINES FOR USAGE

■ For cautions for use, please read " GUIDELINES FOR RELAY USAGE ".
https://industry.panasonic.com/global/en/products/control/relay/cautions_use

■ Cautions for usage of NC relay

- Because the NC relay is polarized, the positive (+) and negative (-) connections to the coil should be done as indicated on the wiring diagram. If connected incorrectly, it may malfunction or fail to operate.
 - While NC relays can be used with any transmission-wave current to their operation, due to slight weakening of the force of magnetic attraction, decreased resistance to vibration and shock should be taken into account.
- When designing top and bottom view schematic diagrams, note that:
- 1) " Top view " wiring diagram is indicated for the flat type because terminals can be seen from above.

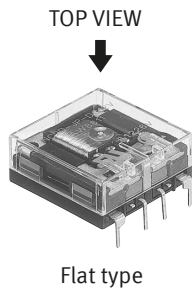

- 2) " Bottom view " schematic diagram is indicated for the slim type because terminals cannot be seen from above.

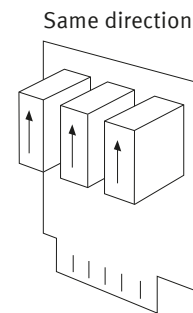
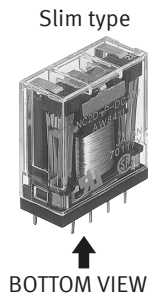

Sockets/DIN terminal sockets

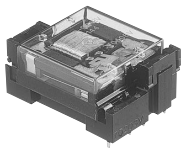

NC2 Flat type socket

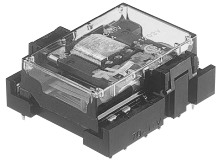

NC4 Flat type socket



NC2 Slim type socket

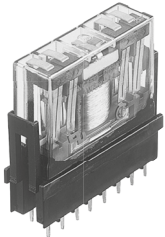

NC4 Slim type socket



NC2 DIN terminal socket

TYPES

Type	Product name	Terminal connection method	Type No.	Part No.	Main Part No. to be installed	Standard packing	
						Inner carton	Outer carton
Flat type socket	NC2-flat type PC board socket	PC board	NC2-JPS	AW4920	AW881 series	20 pcs.	200 pcs.
	NC4-flat type PC board socket	PC board	NC4-JPS	AW4940	AW884 series		
Slim type DIN terminal socket	NC2-DIN terminal socket	DIN rail	NC2-SFD	AW4928	AW821 series	20 pcs.	100 pcs.
Slim type socket	NC2-slim type soldering socket	Solder terminal	NC2-SS	AW4922	AW821 series	20 pcs.	200 pcs.
	NC2-slim type PC board socket	PC board	NC2-PS	AW4924			
	NC2-slim type wrapping socket	Lead wire	NC2-WS	AW4926			
	NC4-slim type soldering socket	Solder terminal	NC4-SS	AW4942	AW824 series		
	NC4-slim type PC board socket	PC board	NC4-PS	AW4944			
NC4-slim type wrapping socket	Lead wire	NC4-WS	AW4946				

RATING

Item	Specifications
Dielectric strength (initial)	Each between terminals: 2,000 Vrms for 1 min (detection current: 10 mA)
Insulation resistance (initial)	Each between terminals: Min. 100 MΩ (at 500 V DC, Measured portion is the same as the case of dielectric strength.)
Max. continuous carrying current	Slim type : 5 A 250 V AC Flat type : 5 A 250 V AC
Conditions for usage, transport and storage	Ambient temperature: -50 to +50 °C (AW4924, AW4926, AW4928, AW4944, AW4946) -40 to +70 °C (AW4920, AW4922, AW4940, AW4942) Humidity: 5 to 85 % RH (Avoid icing and condensation)

Power Relays (Over 2 A) NC RELAYS

DIMENSIONS (Unit: mm)

CAD The CAD data of the products with a " CAD " mark can be downloaded from our Website.

Flat type PC board socket

- NC2 (AW4920)

CAD

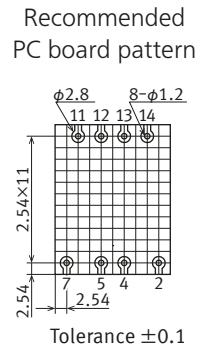
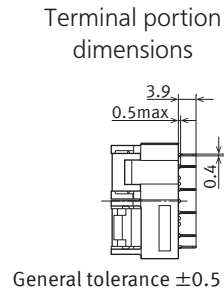
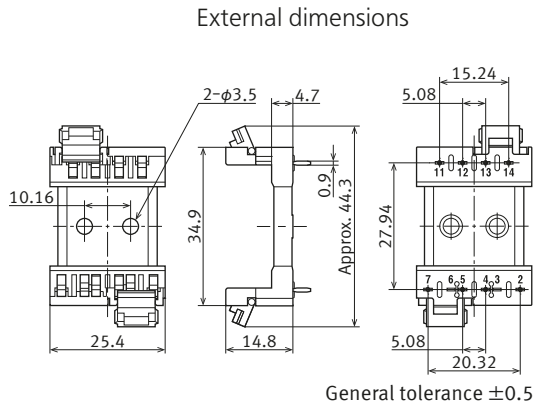
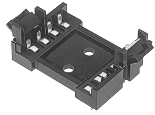

- NC4 (AW4940)

CAD

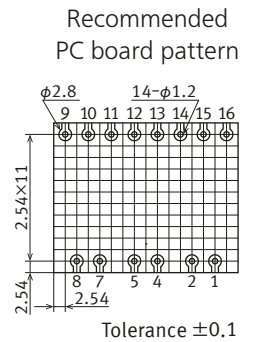
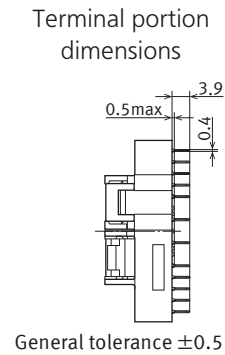
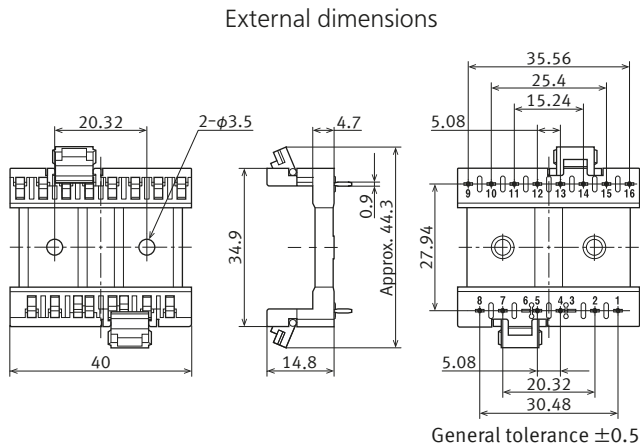
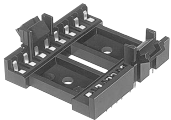

Slim type DIN terminal socket

- NC2 (AW4928)

CAD

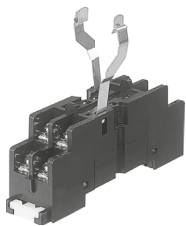

Note: Fastening brackets are included with the DIN terminal socket.

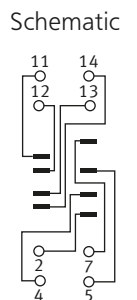
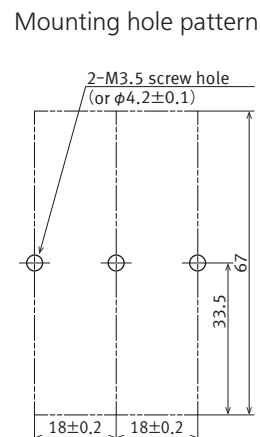
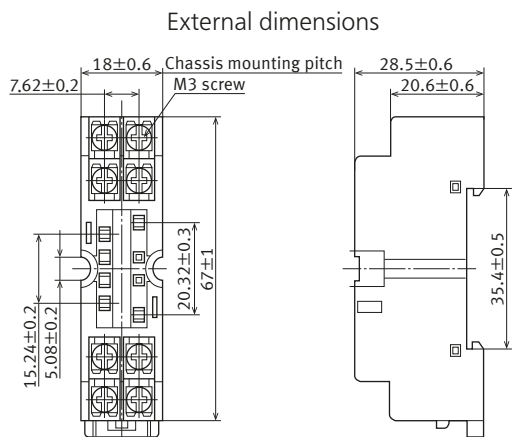

Power Relays (Over 2 A) NC RELAYS

■ Slim type soldering socket

● NC2 (AW4922)

CAD

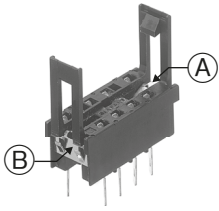

External dimensions

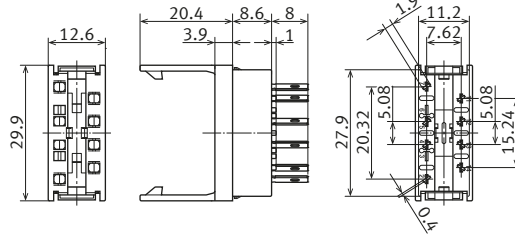

General tolerance ± 0.5

Chassis cutout

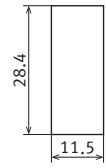

Tolerance ± 0.1

Notes:
1. Suitable chassis thickness is 1.0 to 2.0mm.
2. Once the socket is inserted from above into the mounting holes, the relay will snap in to clips rising from either side at (A) and (B) by pushing.

● NC4 (AW4942)

CAD

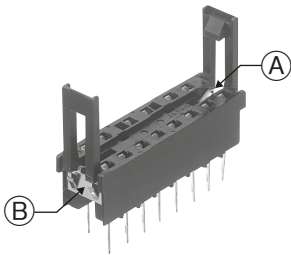

External dimensions

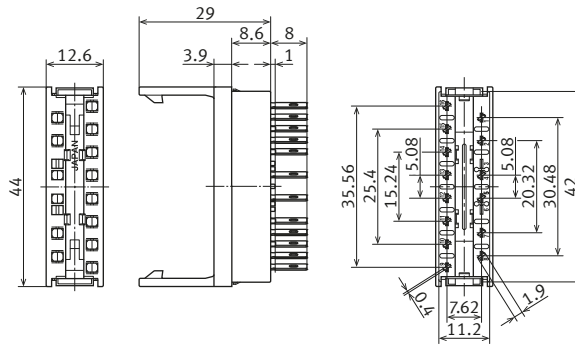

General tolerance ± 0.5

Chassis cutout

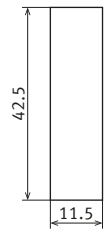

Tolerance ± 0.1

Notes:
1. Suitable chassis thickness is 1.0 to 2.0mm.
2. Once the socket is inserted from above into the mounting holes, the relay will snap in to clips rising from either side at (A) and (B) by pushing.

■ Slim type PC board socket

● NC2 (AW4924)

CAD



External dimensions

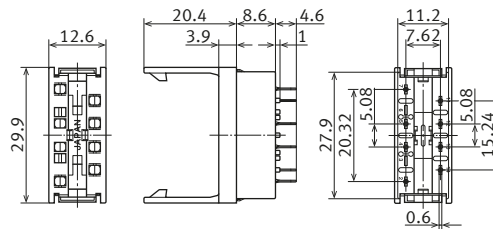

General tolerance ± 0.5

Recommended PC board pattern

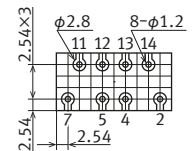

Tolerance ± 0.1

● NC4 (AW4944)

CAD

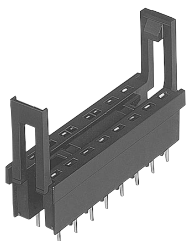

External dimensions

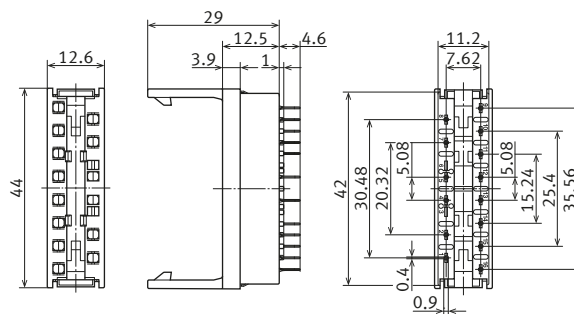

General tolerance ± 0.5

Recommended PC board pattern

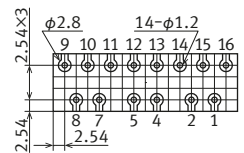

Tolerance ± 0.1

Power Relays (Over 2 A) NC RELAYS

■ Slim type wrapping socket

● NC2 (AW4926)

CAD

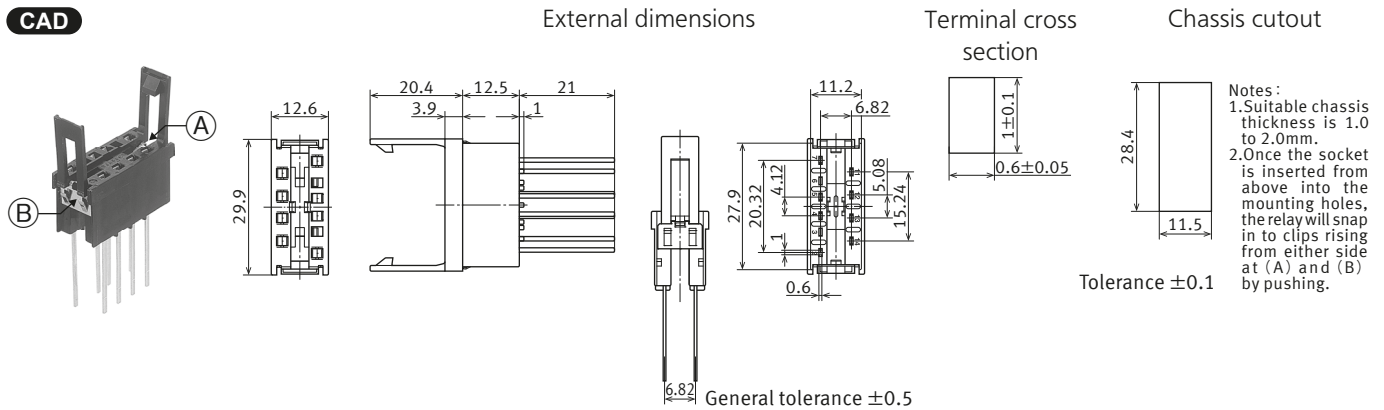

● NC4 (AW4946)

CAD

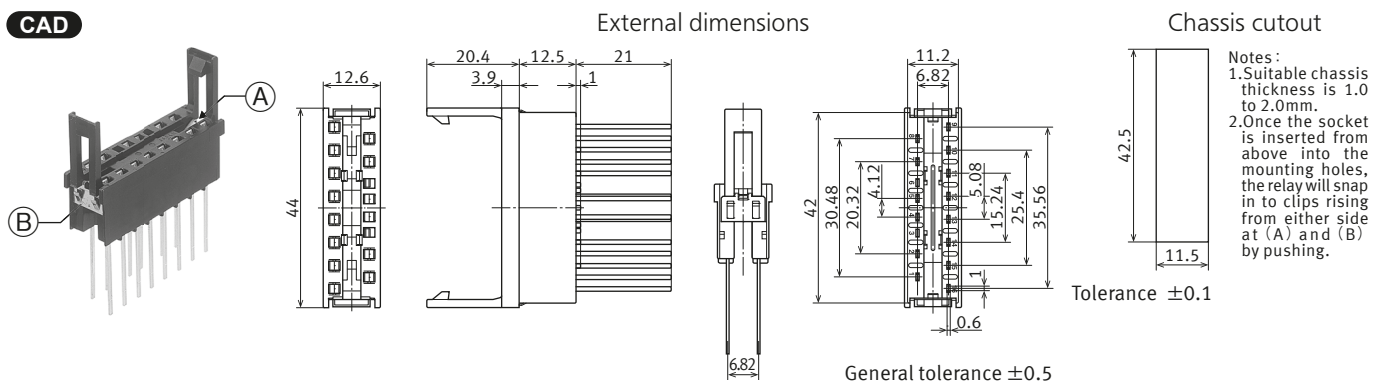

HANDLING

■ Flat type socket

● Mounting method of relay

- 1) Match the direction of relay and socket.

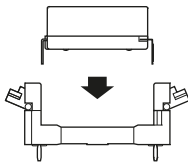

- 2) Insert both ends of the relay firmly, all the way in.



- 3) Press the hooks in the direction of the arrows to attach the relay securely.

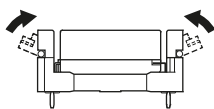

● Removing method of relay

- 1) Pull out the relay after fully releasing both hooks.

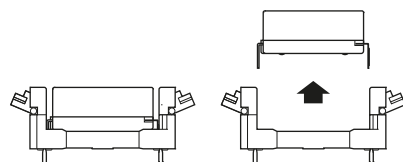

- 2) Take care not to push or spread the hooks more than necessary when installing or removing the relay, because doing so may cause deformation which will prevent the hooks from engaging with the relay, or the hooks may break.

Power Relays (Over 2 A) NC RELAYS

■ Slim type DIN terminal socket

Install the fastening bracket before mounting the relay.

● Mounting method of fastening bracket

- Press the fastening bracket into the terminal socket until it stops and check that the claw has engaged with the terminal socket.

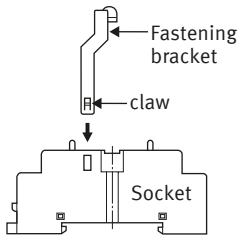

● Mounting method of relay

- 1) Match the direction of relay and terminal socket.

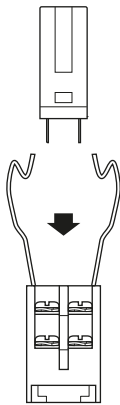

- 2) Insert both ends of the relay firmly, all the way in.

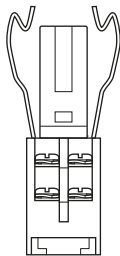

- 3) With the included fastening bracket, securely attach the relay.

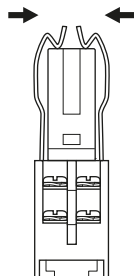

● Removing method of fastening bracket

- Pull out the fastening bracket while pressing the tab with a screwdriver or similar.

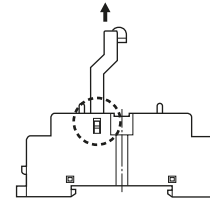

● Removing method of relay

- 1) Pull out the relay after fully releasing fastening bracket.

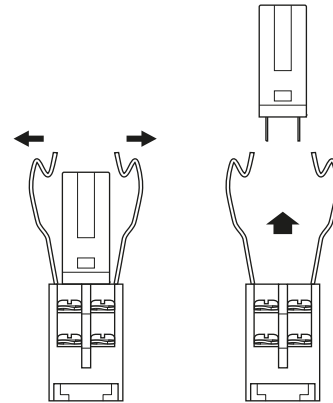

- 2) Take care not to push or spread the hooks more than necessary when installing or removing the relay, because doing so may cause deformation which will prevent the hooks from engaging with the relay, or the hooks may break.

Power Relays (Over 2 A) NC RELAYS

■ Slim type socket

● Mounting method of relay

1) Match the direction of relay and socket.

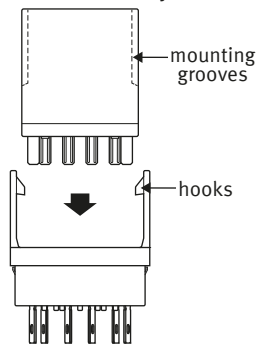

2) Insert both ends of the relay securely and all the way until both hooks engage with the mounting grooves.

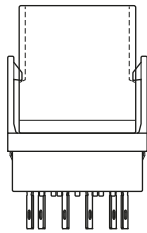

● Removing method of relay

1) Pull out the relay while pressing and spreading the hooks.

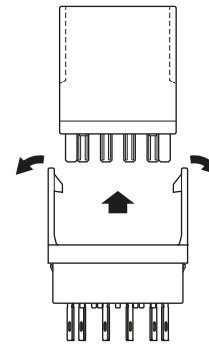

2) Take care not to push or spread the hooks more than necessary when installing or removing the relay, because doing so may cause deformation which will prevent the hooks from engaging with the relay, or the hooks may break.

GUIDELINES FOR USAGE

- For solder terminal types, connect terminals as shown in the diagram to maintain insulation distance.

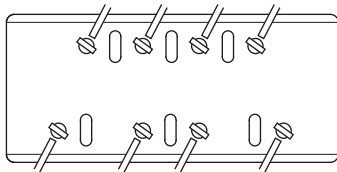

- For cautions for use, please read " GUIDELINES FOR RELAY USAGE ".
https://industry.panasonic.com/global/en/products/control/relay/cautions_use

Precautions for Coil Input

■ Long term current carrying

A circuit that will be carrying a current continuously for long periods without relay switching operation. (circuits for emergency lamps, alarm devices and error inspection that, for example, revert only during malfunction and output warnings with form B contacts) Continuous, long-term current to the coil will facilitate deterioration of coil insulation and characteristics due to heating of the coil itself. For circuits such as these, please use a magnetic-hold type latching relay. If you need to use a single stable relay, use a sealed type relay that is not easily affected by ambient conditions and make a failsafe circuit design that considers the possibility of contact failure or disconnection.

■ DC Coil operating power

Steady state DC current should be applied to the coil. The wave form should be rectangular. If it includes ripple, the ripple factor should be less than 5 %. However, please check with the actual circuit since the electrical characteristics may vary. The rated coil voltage should be applied to the coil and the set/reset pulse time of latching type relay differs for each relays, please refer to the relay's individual specifications.

■ Coil connection

When connecting coils of polarized relays, please check coil polarity (+ , -) at the internal connection diagram (Schematic). If any wrong connection is made, it may cause unexpected malfunction, like abnormal heat, fire and so on, and circuit do not work. Avoid impressing voltages to the set coil and reset coil at the same time.

■ Maximum allowable voltage and temperature rise

Proper usage requires that the rated coil voltage be impressed on the coil. Note, however, that if a voltage greater than or equal to the maximum continuous voltage is impressed on the coil, the coil may burn or its layers short due to the temperature rise. Furthermore, do not exceed the usable ambient temperature range listed in the catalog.

● Operate voltage change due to coil temperature rise

In DC relays, after continuous passage of current in the coil, if the current is turned OFF, then immediately turned ON again, due to the temperature rise in the coil, the operate voltage will become somewhat higher. Also, it will be the same as using it in a higher temperature atmosphere. The resistance/temperature relationship for copper wire is about 0.4 % for 1 °C, and with this ratio the coil resistance increases. That is, in order to operate of the relay, it is necessary that the voltage be higher than the operate voltage and the operate voltage rises in accordance with the increase in the resistance value. However, for some polarized relays, this rate of change is considerably smaller.

Ambient Environment

Usage, Transport, and Storage Conditions

During usage, storage, or transportation, avoid locations subjected to direct sunlight and maintain normal temperature, humidity and pressure conditions.

Temperature/Humidity/Pressure

When transporting or storing relays while they are tube packaged, there are cases the temperature may differ from the allowable range. In this case be sure to check the individual specifications.

Also allowable humidity level is influenced by temperature, please check charts shown below and use relays within mentioned conditions. (Allowable temperature values differ for each relays, please refer to the relay's individual specifications.)

1) Temperature:

The tolerance temperature range differs for each relays, please refer to the relay's individual specifications

2) Humidity: 5 to 85 % RH

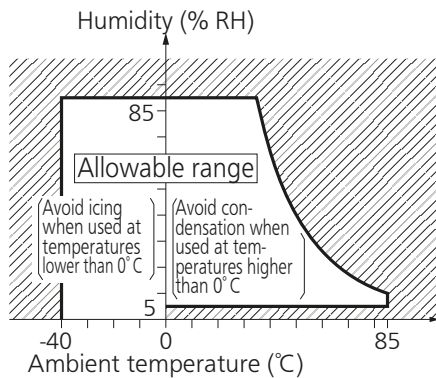

3) Pressure: 86 to 106 kPa

Dew condensation

Condensation occurs when the ambient temperature drops suddenly from a high temperature and humidity, or the relay is suddenly transferred from a low ambient temperature to a high temperature and humidity.

Condensation causes the failures like insulation deterioration, wire disconnection and rust etc.

Panasonic Industry Co., Ltd. does not guarantee the failures caused by condensation.

The heat conduction by the equipment may accelerate the cooling of device itself, and the condensation may occur.

Please conduct product evaluations in the worst condition of the actual usage. (Special attention should be paid when high temperature heating parts are close to the device. Also please consider the condensation may occur inside of the device.)

Icing

Condensation or other moisture may freeze on relays when the temperature become lower than 0 °C. This icing causes the sticking of movable portion, the operation delay and the contact conduction failure etc. Panasonic Industry Co., Ltd. does not guarantee the failures caused by the icing.

The heat conduction by the equipment may accelerate the cooling of relay itself and the icing may occur.

Please conduct product evaluations in the worst condition of the actual usage.

Low temperature and low humidity

The plastic becomes brittle if the relay is exposed to a low temperature, low humidity environment for long periods of time.

High temperature and high humidity

Storage for extended periods of time (including transportation periods) at high temperature or high humidity levels or in atmospheres with organic gases or sulfide gases may cause a sulfide film or oxide film to form on the surfaces of the contacts and/or it may interfere with the functions. Check out the atmosphere in which the units are to be stored and transported.

Package

In terms of the packing format used, make every effort to keep the effects of moisture, organic gases and sulfide gases to the absolute minimum.

Silicon

When a source of silicone substances (silicone rubber, silicone oil, silicone coating materials and silicone filling materials etc.) is used around the relay, the silicone gas (low molecular siloxane etc.) may be produced.

This silicone gas may penetrate into the inside of the relay. When the relay is kept and used in this condition, silicone compound may adhere to the relay contacts which may cause the contact failure. Do not use any sources of silicone gas around the relay (Including plastic sealed types).

NOx Generation

When relay is used in an atmosphere high in humidity to switch a load which easily produces an arc, the NOx created by the arc and the water absorbed from outside the relay combine to produce nitric acid.

This corrodes the internal metal parts and adversely affects operation.

Avoid use at an ambient humidity of 85 % RH or higher (at 20 °C). If use at high humidity is unavoidable, please contact our sales representative.

Others

■ Cleaning

- Although the environmentally sealed type relay (plastic sealed type, etc.) can be cleaned, avoid immersing the relay into cold liquid (such as cleaning solvent) immediately after soldering. Doing so may deteriorate the sealing performance.
- Cleaning with the boiling method is recommended (The temperature of cleaning liquid should be 40 °C or lower). Avoid ultrasonic cleaning on relays. Use of ultrasonic cleaning may cause breaks in the coil or slight sticking of the contacts due to ultrasonic energy.

Please refer to " **the latest product specifications** " when designing your product.

- Requests to customers:

<https://industry.panasonic.com/global/en/salespolicies>

■ Global Sales Network Information: industry.panasonic.com/global/en/salesnetwork/globalnetwork

Panasonic
INDUSTRY

Panasonic Industry Co., Ltd.

Electromechanical Control Business Division

■ 1006, Oaza Kadoma, Kadoma-shi, Osaka 571-8506, Japan
industry.panasonic.com